

Globe Valve

**NORI 320 ZXSV**

**Type Series Booklet**



## **Legal information/Copyright**

Type Series Booklet NORI 320 ZXS V

All rights reserved. The contents provided herein must neither be distributed, copied, reproduced, edited or processed for any other purpose, nor otherwise transmitted, published or made available to a third party without the manufacturer's express written consent.

Subject to technical modification without prior notice.

© KSB SE & Co. KGaA, Frankenthal 2023-02-03

---

## Contents

<b>Globe Valves.....</b>	<b>4</b>
Globe Valves to DIN/EN with Gland Packing .....	4
NORI 320 ZXSV .....	4
Main applications.....	4
Fluids handled .....	4
Operating data.....	4
Valve body materials.....	4
Design details .....	4
Product benefits.....	5
Product information .....	5
Related documents .....	5
Purchase order specifications .....	5
Pressure/temperature ratings.....	6
Materials.....	7
Variants.....	8
Dimensions and weights.....	9
Installation instructions .....	10

## Globe Valves

### Globe Valves to DIN/EN with Gland Packing

# NORI 320 ZXSV



#### Main applications

- Fossil-fuelled power stations
- Boiler feed applications
- Process engineering
- Petrochemical industry
- Chemical industry
- Shipbuilding
- Paper industry / pulp industry
- Sugar industry
- Descaling units
- Mining
- Nuclear power stations

#### Fluids handled

- Water
- Steam
- Other non-aggressive fluids such as gas or oil on request.

#### Operating data

Table 1: Operating properties

Characteristic	Value
Nominal pressure	PN 250 - 320
Nominal size	DN 10 - 50
Max. permissible pressure [bar]	320
Min. permissible temperature [°C]	≥ -10
Max. permissible temperature [°C]	≤ +580

Selection as per pressure/temperature ratings (⇒ Page 6)

#### Valve body materials

Table 2: Overview of available materials

Material	Material number	Temperature limit
16 Mo 3	1.5415	≤ 530 °C
13 CrMo 4-5	1.7335	≤ 550 °C
10 CrMo 9-10/ 11 CrMo 9-10	1.7380/ 1.7383	≤ 580 °C

Other materials on request.

#### Design details

##### Design

- Straight-way pattern
- Throttling plug
- Forged body and yoke
- Bonnetless, with single-piece body
- Stem sealed by gland packing with packing end rings
- Non-rotating stem
- Position indicator
- Seat/disc interface made of wear-resistant and corrosion-proof Stellite
- EC type tested (Module B), component mark TÜ.A. 301
- Threaded bush free from non-ferrous metals

##### Variants

- Valve combination with connecting pipe
- Locking device
- Gland follower with scraper ring
- Other butt weld end versions
- Other socket weld end versions
- Inspections to technical codes such as AD2000 or to customer specification

**Product benefits**

- Easy to assemble and disassemble with bayonet-type body/ yoke connection
- Service-friendly design with single-piece body. No bonnet bolting that needs to be retightened.
- Additional features ensure safe sealing to atmosphere:
  - Risk of leakage is reduced by valve design without bonnet gasket.
  - Graphite gland packing with packing end rings, protected against oxidation by metal caps.
- One model for shut-off and throttling thanks to standard throttling plug for all nominal sizes. Reduces numbers of spares and spare parts stock.
- Stem with burnished shank for long service life and high functional reliability of the gland packing
- Hard-faced valve seat made of wear-resistant and corrosion-proof Stellite.

**Product information**

**Product information as per Regulation No. 1907/2006 (REACH)**

For information as per European chemicals regulation (EC) No. 1907/2006 (REACH) see <https://www.ksb.com/en-global/company/corporate-responsibility/reach>.

**Product information as per Directive 2014/34/EU (ATEX)**

The valves do not have a potential internal source of ignition and can be used in potentially explosive atmospheres, Group II, category 2 (zones 1+21) and category 3 (zone 2+22) to ATEX 2014/34/EU.

**Product information as per Pressure Equipment Directive 2014/68/EU (PED)**

The valves satisfy the safety requirements of Annex I of the European Pressure Equipment Directive 2014/68/EU (PED) for fluids in Groups 1 and 2.

**Product information as per UK Equipment and Protective Systems Intended for Use in Potentially Explosive Atmospheres Regulations 2016**

The valves do not have a potential internal source of ignition and can be used in accordance with the UK's Equipment and Protective Systems Intended for Use in Potentially Explosive Atmospheres Regulations 2016 in potentially explosive atmospheres, Group II, category 2 (zones 1+21) and category 3 (zone 2+22).

**Product information as per UK Pressure Equipment (Safety) Regulations 2016**

The valves satisfy the safety requirements of the UK Pressure Equipment (Safety) Regulations 2016 (PER) for fluids in Groups 1 and 2.

**Related documents**

**Table 3:** Information/documents

Document	Reference number
NORI 500 ZXSV type series booklet (globe valves, bonnetless, with single-piece body)	7641.1
Operating manual	0570.82

**Purchase order specifications**

Please specify the following information in all enquiries or purchase orders:

1. Type
2. Nominal pressure
3. Nominal size
4. Operating pressure
5. Differential pressure
6. Operating temperature
7. Material
8. Fluid handled
9. Flow rate
10. Pipe connection
11. Variants
12. Reference number

Always indicate the original serial number and the year of construction when ordering spare parts.

**Pressure/temperature ratings**

**Socket weld ends (to DIN EN 12760) and butt weld ends (to DIN EN 12627), machined; and butt weld ends, unmachined**

**Table 4:** Permissible operating pressure [bar]<sup>1)</sup>

PN	Material		[°C]																		
	Designation	Number	Up to 100	150	200	250	300	350	400	425	450	475	500	510	520	530	540	550	560	570	580
250	16 Mo 3	1.5415	250,0	250,0	250,0	244,0	214,2	202,3	186,9	179,7	172,6	141,6	110,7	88,0	70,2	55,9	-	-	-	-	-
	13 CrMo 4-5	1.7335	250,0	250,0	250,0	250,0	250,0	238,0	225,0	217,8	210,7	185,2	163,0	138,0	111,9	92,8	72,6	58,3	-	-	-
	10 CrMo 9-10 / 11 CrMo 9-10	1.7380 / 1.7383	250,0	250,0	250,0	250,0	250,0	244,0	232,1	226,0	220,2	190,4	160,7	140,4	122,6	107,1	92,8	80,9	69,0	60,7	52,3
320	16 Mo 3	1.5415	320,0	320,0	320,0	312,3	274,2	259,0	239,2	230,0	220,9	181,3	141,7	112,7	89,9	71,6	-	-	-	-	-
	13 CrMo 4-5	1.7335	320,0	320,0	320,0	320,0	304,7	288,0	278,8	269,7	237,1	208,7	176,7	143,2	118,8	92,9	74,6	-	-	-	-
	10 CrMo 9-10 / 11 CrMo 9-10	1.7380 / 1.7383	320,0	320,0	320,0	320,0	320,0	312,3	297,1	289,5	281,9	243,7	205,7	179,8	156,9	137,1	118,8	103,6	88,3	77,7	67,0

**Socket weld ends and butt weld ends machined to customer specifications, and butt weld ends unmachined**

**Table 5:** Permissible operating pressure [bar]<sup>1)</sup>

PT	Material		[°C]																		
	Designation	Number	Up to 100	150	200	250	300	350	400	425	450	475	500	510	520	530	540	550	560	570	580
- 2)	16 Mo 3	1.5415	320,0	320,0	320,0	320,0	320,0	318,0	298,0	293,0	288,0	283,0	179,0	136,0	107,0	86,0	-	-	-	-	-
	13 CrMo 4-5	1.7335	320,0	320,0	320,0	320,0	320,0	320,0	320,0	320,0	320,0	315,0	274,0	229,0	181,0	148,0	119,0	93,0	-	-	-
	10 CrMo 9-10 / 11 CrMo 9-10	1.7380 / 1.7383	320,0	320,0	320,0	320,0	320,0	320,0	320,0	320,0	320,0	320,0	280,0	244,0	213,0	186,0	161,0	138,0	119,0	102,0	88,0

In the case of machined weld ends, the permissible operating pressures are governed by the actual dimensions obtained.

<sup>1</sup> The valves are suitable for temperatures down to -10 °C.

<sup>2</sup> - Valve selection per pressure and temperature (PT)

Materials

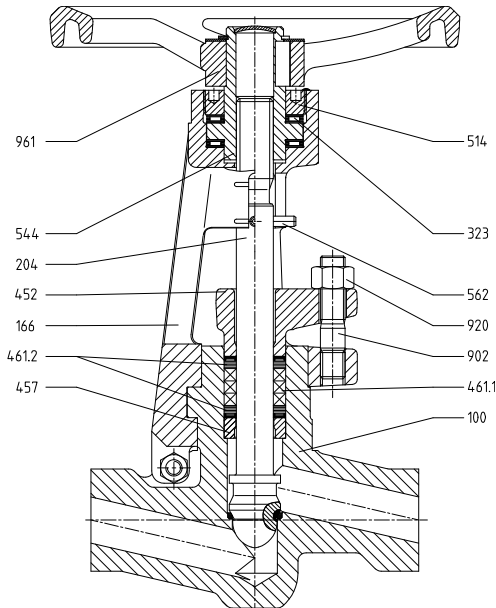

Fig. 1: Sectional drawing of NORI 320 ZXSV

Table 6: Parts list

Part No.	Description	Temperature [°C]	Material	Material number	Note	Seat/disc interface
100	Body	≤ 530	16 Mo 3	1.5415	Die-forged	Stellited
		≤ 550	13 CrMo 4-5	1.7335		
		≤ 580	10 CrMo 9-10 / 11 CrMo 9-10	1.7380 / 1.7383		
166	Yoke	≤ 580	13 CrMo 4-5	1.7335	Die-forged	-
204 <sup>3)</sup>	Stem and throttling plug assembly		X 39 CrMo 17-1	1.4122	-	Stellited
323 <sup>3)</sup>	Thrust needle bearing		Steel	-	-	-
452	Gland follower		13 CrMo 4-5	1.7335	Die-forged	-
457 <sup>3)</sup>	Neck ring		G X 70 CrMo 29-2	1.4136	-	-
461.1 <sup>3)</sup>	Packing ring		Pure graphite	-	Packing end rings/ stainless steel cap	-
461.2 <sup>3)</sup>			Graphite / 1.4571	-		-
514	Threaded ring		11 SMnPb30	1.0718	-	-
544 <sup>3)</sup>	Threaded bush		45 S20	1.0727	Gas-nitrocarburised	-
562	Anti-rotation pin		Steel	-	-	-
902	Stud		21 CrMoV 5-7	1.7709	-	-
920	Hexagon nut		25 CrMo 4	1.7218	-	-
961	Handwheel		EN-GJS-400-15	5.3106	-	-

<sup>3</sup> Recommended spare parts

Variants

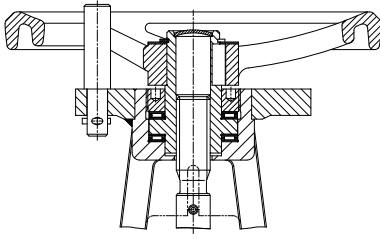

Locking  
device

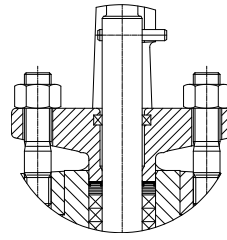

Gland follower with scraper ring



## Dimensions and weights

### Dimensions and weights of NORI 320 ZXSV

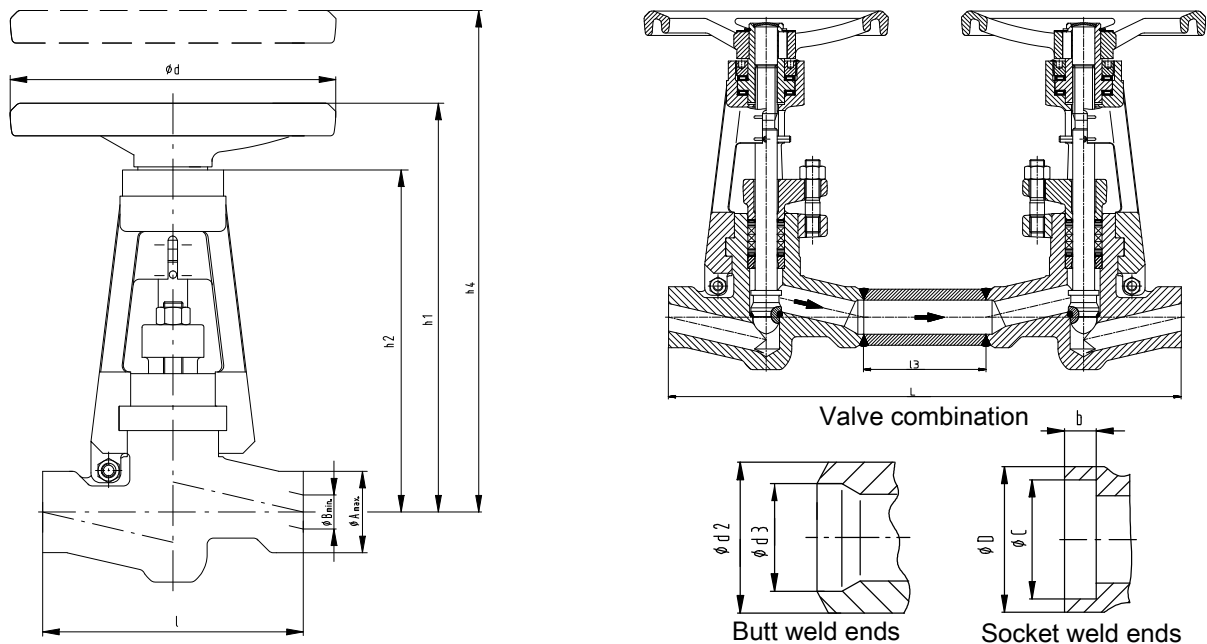

Fig. 2: NORI 320 ZXSV, valve combination<sup>4)</sup>

Table 7: Dimensions and weights

PN	DN	I	Butt weld ends, unmachined		Butt weld ends to DIN EN 12627						Socket weld ends to DIN EN 12760 PN 320 <sup>5)</sup>			$h_1^{6)}$	$h_2$	$h_4^{7)}$	$\phi d$	[kg]
			$\phi A_{max.}$	$\phi B_{min.}$	$\phi d_2$	PN 250		$\phi d_2$	PN 320		$\phi D_{-0,5}$	$\phi C_{+0,2}$	$b_{min.}$					
						$\phi d_3$	Pipe dimensions		$\phi d_3$	Pipe dimensions								
[mm]	[mm]	[mm]	[mm]	[mm]	[mm]	[mm]	[mm]	[mm]	[mm]	[mm]	[mm]	[mm]	[mm]	[mm]	[mm]	[mm]	[mm]	
320	10	150,0	35,0	9,0	18,0	12,0	17,2 × 2,6	18,0	11,5	17,2 × 2,9	27,0	17,6	10,0	225,0	195,0	315,0	160,0	5,5
	15	150,0	35,0	14,0	22,0	16,0	21,3 × 2,6	22,0	15,0	21,3 × 3,2	32,5	21,8	10,0	225,0	195,0	315,0	160,0	5,5
	20	160,0	50,0	19,0	28,0	20,0	26,9 × 3,6	28,0	19,0	26,9 × 4,0	39,5	27,2	13,0	250,0	215,0	360,0	200,0	8,0
	25	160,0	50,0	22,0	35,0	26,5	33,7 × 3,6	35,0	24,0	33,7 × 5,0	48,0	33,9	13,0	250,0	215,0	360,0	200,0	8,0
	32	250,0	78,0	30,0	44,0	34,0	42,4 × 4,5	44,0	30,5	42,4 × 6,3	57,5	42,7	13,0	305,0	265,0	430,0	250,0	18,0
	40	250,0	78,0	35,0	50,0	39,0	48,3 × 5,0	50,0	36,0	48,3 × 6,3	65,5	48,8	13,0	305,0	265,0	430,0	250,0	18,0
50	250,0	78,0	35,0	62,0	48,0	60,3 × 6,3	62,0	46,5	60,3 × 7,1	77,0	61,2	16,0	305,0	265,0	430,0	250,0	18,0	

Table 8: Dimensions and weights of valve combination

DN	Valve combination		
	$l_3$	L	[kg]
	[mm]	[mm]	
10 - 15	60,0	360,0	12,0
20 - 25	100,0	420,0	18,0
32 - 50	60,0	560,0	38,0

### Mating dimensions as per standard

Face-to-face lengths: See table  
 Butt weld ends: DIN EN 12627 figure 2, type B  
 Socket weld ends: DIN EN 12760

Different designs of butt weld ends, socket weld ends and welding groove types are possible, but only within the dimensions  $A_{max.}$  and  $B_{min.}$ .

<sup>4</sup> Drain lines, vent lines or manual start-up lines are normally fitted with valve combinations consisting of a shut-off valve (pressure beneath the valve disc) and a throttling valve (pressure above the valve disc).

<sup>5</sup> DN 50: PN 250 only; socket weld ends for higher pressures on request

<sup>6</sup> Open

<sup>7</sup> Vertical clearance for removal

Butt weld ends to DIN 3239/1 and/or socket weld ends to ASME B16.11 and DIN 3239/2 are possible.

### Installation instructions

**Shut-off globe valves** must be installed in the line so as to ensure that the fluid enters the valve beneath the valve disc and flows out above the valve disc. They can also be installed in lines with alternating flow.

**For globe valves with throttling plug, detailed information about the operating mode is required for optimum valve selection. For throttling valves, it is recommended to have the pressure above the valve disc.**





**KSB SE & Co. KGaA**  
Bahnhofplatz 1 • 91257 Pegnitz (Germany)  
Tel. +49 9241 71-0  
[www.ksb.com](http://www.ksb.com)