

Globe Valve

NORI 160 ZXLF/ZXSF

Type Series Booklet



Legal information/Copyright

Type Series Booklet NORI 160 ZXLF/ZXSF

All rights reserved. The contents provided herein must neither be distributed, copied, reproduced, edited or processed for any other purpose, nor otherwise transmitted, published or made available to a third party without the manufacturer's express written consent.

Subject to technical modification without prior notice.

© KSB SE & Co. KGaA, Frankenthal 2022-11-30

Contents

Globe Valves.....	4
Globe Valves to DIN/EN with Gland Packing	4
NORI 160 ZXLF/ZXSF	4
Main applications.....	4
Fluids handled	4
Operating data.....	4
Valve body materials.....	4
Design details	4
Product benefits.....	5
Product information	5
Related documents	5
Purchase order specifications	5
Pressure/temperature ratings.....	6
Materials.....	6
Variants.....	8
Dimensions and weights.....	9
Installation instructions	12

Globe Valves

Globe Valves to DIN/EN with Gland Packing

NORI 160 ZXLF/ZXSF

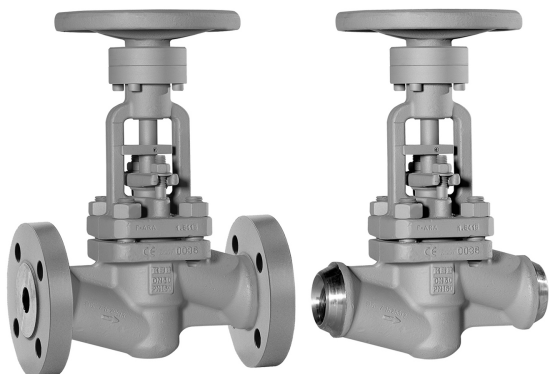

Main applications

- Fossil-fuelled power stations
- Boiler feed applications
- Process engineering
- Petrochemical industry
- Chemical industry
- Shipbuilding
- Paper industry / pulp industry
- Sugar industry
- Condensate transport
- Descaling units
- Snow-making systems
- Mining
- Nuclear power stations

Fluids handled

- Water
- Steam
- Other non-aggressive fluids such as gas or oil on request.

Operating data

Table 1: Operating properties

Characteristic	Value
Nominal pressure	PN 63 - 160
Nominal size	DN 10 - 200
Max. permissible pressure [bar]	160
Min. permissible temperature [°C]	≥ -10
Max. permissible temperature [°C]	≤ +550

Selection as per pressure/temperature ratings (⇒ Page 6)

Valve body materials

Overview of materials available for model with flanged ends, DN 10-25

Table 2: Overview of available materials

Material	Material number	Temperature limit
P 250 GH	1.0460	≤ 450 °C
13 CrMo 4-5	1.7335	≤ 550 °C

Overview of materials available for model with butt weld ends, DN 10-50

Table 3: Overview of available materials

Material	Material number	Temperature limit
16 Mo 3	1.5415	≤ 530 °C
13 CrMo 4-5	1.7335	≤ 550 °C

Overview of materials available for model with flanged ends, DN 32-200, and for model with butt weld ends, DN 65-200

Table 4: Overview of available materials

Material	Material number	Temperature limit
GP 240 GH+N	1.0619+N	≤ 450 °C
G 17 CrMo 5-5	1.7357	≤ 550 °C

Design details

Design

- Straight-way pattern
- On/off disc DN 10 - 100
- Balanced plug ≥ DN 125
- Non-rotating stem
- Position indicator
- Seat/disc interface made of wear and corrosion-resistant chrome steel (Cr) or stellite
- Stem sealed by gland packing
- Fully confined bonnet gasket
- Corrosion-protected bolts/screws and nuts
- Yoke head suitable for mounting electric and pneumatic actuators (DIN ISO 5210)
- Type-tested to TRD 110, TRB 801 No. 45 TÜ.A. 237 (DN 10-50)

Variants

- Throttling plug ≥ DN 65
- Single-piece stem and throttling plug assembly
- Balanced plug ≥ DN 65
- Stellite seat/disc interface (standard for 1.7335/1.7357)
- Oil and grease free (wetted parts)
- Limit switch(es)
- Threaded bush free from non-ferrous metals (DN 65 and above)
- Actuator installation kit
- Hard-faced back seat from DN 65
- Connection branches made of 16 Mo 3 (≥ DN 65)

- Other flange designs
- Other butt weld end versions
- Other socket weld end versions
- Inspections to technical codes such as TRD/TRB/AD2000 – German Steam Boiler / Pressure Vessel Regulations – or to customer specification

Product benefits

- Standard DIN/ISO top flange at the yoke head simplifies actuator mounting. No modifications required. No need to dismantle pressure-retaining components.
- Additional features ensure safe sealing to atmosphere:
 - Serrated bonnet gasket, fully confined to prevent creep.
 - Graphite gland packing with packing end rings.
- Additional safety and blow-out protection by standard back seat.
- Long service life and high functional reliability
 - of the gland packing due to non-rotating stem with burnished shank.
 - Threaded bush runs in ball bearings for smooth actuation.
 - Hard-faced valve seat made of wear-resistant and corrosion-proof 17 % chrome steel or Stellite.
- Easy to repair due to corrosion-protected bolts/screws and nuts

Product information

Product information as per Regulation No. 1907/2006 (REACH)

For information as per European chemicals regulation (EC) No. 1907/2006 (REACH) see <https://www.ksb.com/en-global/company/corporate-responsibility/reach>.

Product information as per Directive 2014/34/EU (ATEX)

The valves do not have a potential internal source of ignition and can be used in potentially explosive atmospheres, Group II, category 2 (zones 1+21) and category 3 (zone 2+22) to ATEX 2014/34/EU.

Product information as per Pressure Equipment Directive 2014/68/EU (PED)

The valves satisfy the safety requirements of Annex I of the European Pressure Equipment Directive 2014/68/EU (PED) for fluids in Groups 1 and 2.

Product information as per UK Equipment and Protective Systems Intended for Use in Potentially Explosive Atmospheres Regulations 2016

The valves do not have a potential internal source of ignition and can be used in accordance with the UK’s Equipment and Protective Systems Intended for Use in Potentially Explosive Atmospheres Regulations 2016 in potentially explosive atmospheres, Group II, category 2 (zones 1+21) and category 3 (zone 2+22).

Product information as per UK Pressure Equipment (Safety) Regulations 2016

The valves satisfy the safety requirements of the UK Pressure Equipment (Safety) Regulations 2016 (PER) for fluids in Groups 1 and 2.

Related documents

Table 5: Information/documents

Document	Reference number
NORI 160 ZXL/ZXS type series booklet (globe valves with rotating stem)	7361.1
NORI 160 RXL/RXS type series booklet (lift check valves)	7681.1
Operating manual	0570.82

Purchase order specifications

Please specify the following information in all enquiries or purchase orders:

1. Type
2. Nominal pressure
3. Nominal size
4. Operating pressure
5. Differential pressure
6. Operating temperature
7. Material
8. Fluid handled
9. Flow rate
10. Pipe connection
11. Variants
12. Reference number

Always indicate the original serial number and the year of construction when ordering spare parts.

Pressure/temperature ratings

Table 6: Permissible operating pressure [bar] (to EN 1092-1)

PN	Material		[°C]																			
	Designation	Number	RT ¹⁾	100	150	200	250	300	350	400	450	460	470	480	490	500	510	520	530	540	550	
63	P 250 GH	1.0460	63	59	56	53	48	44	41	38	21	-	-	-	-	-	-	-	-	-	-	-
	GP 240 GH+N	1.0619+N	63	59	56	53	48	44	41	38	21	-	-	-	-	-	-	-	-	-	-	-
	13 CrMo 4-5	1.7335	63	63	63	63	63	63	63	60	57	53	51	48	45	43	41	35	28	23	18	15
100	G 17 CrMo 5-5	1.7357	63	63	63	63	63	63	60	57	53	51	48	45	43	41	35	28	23	18	15	
	P 250 GH	1.0460	100	93	88	83	76	69	64	60	33	-	-	-	-	-	-	-	-	-	-	-
	GP 240 GH+N	1.0619+N	100	93	88	83	76	69	64	60	33	-	-	-	-	-	-	-	-	-	-	-
	13 CrMo 4-5	1.7335	100	100	100	100	100	100	95	90	84	80	76	72	68	65	55	45	37	29	23	
160	G 17 CrMo 5-5	1.7357	100	100	100	100	100	100	95	90	84	80	76	72	68	65	55	45	37	29	23	
	P 250 GH	1.0460	160	149	141	133	122	110	103	95	53	-	-	-	-	-	-	-	-	-	-	-
	GP 240 GH+N	1.0619+N	160	149	141	133	122	110	103	95	53	-	-	-	-	-	-	-	-	-	-	-
	16 Mo 3	1.5415	160	160	160	160	156	137	130	120	110	103	95	87	79	71	56	45	36	-	-	-
	13 CrMo 4-5	1.7335	160	160	160	160	160	160	152	144	135	128	122	115	109	104	88	72	59	46	37	
160	G 17 CrMo 5-5	1.7357	160	160	160	160	160	160	152	144	135	128	122	115	109	104	88	72	59	46	37	

Materials

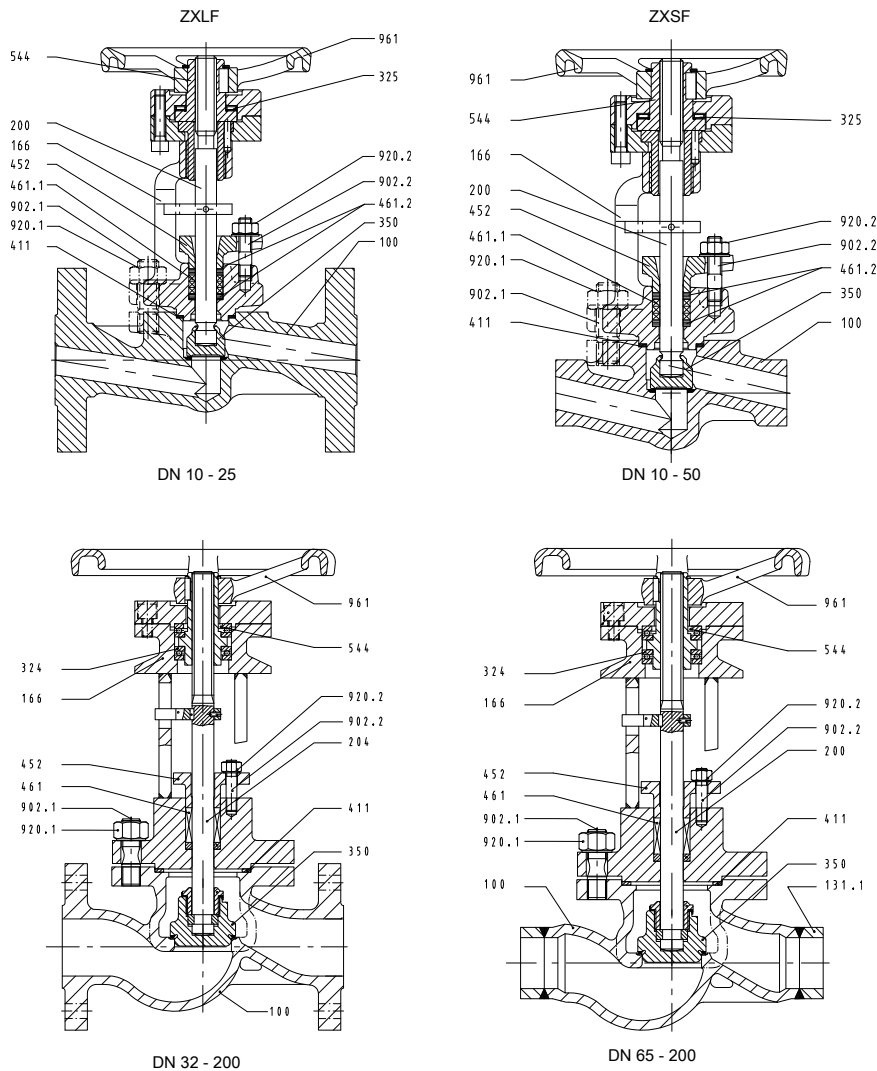

Fig. 1: Sectional drawings

¹ RT: room temperature (-10 °C to +50 °C)

Table 7: Parts list

Part No.	Description	Temperature [°C]	Material	Material number	Note	Seat/disc interface
100	Body	≤ 450	P 250 GH	1.0460	ZXLF ≤ DN 25	17 % chrome steel (Cr)
			GP 240 GH+N	1.0619+N	ZXLF ≥ DN 32, ZXSf ≥ DN 65	
		≤ 530	16 Mo 3	1.5415	ZXSf ≤ DN 50	Stellite
		≤ 550	13 CrMo 4-5	1.7335	ZXLF ≤ DN 25, ZXSf ≤ DN 50	
G 17 CrMo 5-5	1.7357		ZXLF ≥ DN 32, ZXSf ≥ DN 65			
131.1	Connection branch	≤ 450	P 250 GH	1.0460	≥ DN 65	-
		≤ 550	13 CrMo 4-5	1.7335		-
166	Yoke	≤ 530	16 Mo 3	1.5415	≤ DN 50	-
		≤ 550	13 CrMo 4-5	1.7335	-	-
200 ²⁾	Stem	≤ 550	X 39 CrMo 17-1	1.4122	-	-
324	Thrust bearing	≤ 550	Steel	-	≥ DN 65	-
325	Needle bearing				≤ DN 50	-
350 ²⁾	Valve disc	≤ 550	X 39 CrMo 17-1	1.4122	≤ DN 50	-
			13 CrMo 4-5	1.7335	≥ DN 65	Stellite
411 ²⁾	Joint ring	≤ 550	CrNi steel/ graphite	-	Serrated	-
452	Gland follower		P 250 GH	1.0460	-	-
461.1 ²⁾	Packing ring		Graphite	-	-	-
461.2 ²⁾						
544 ²⁾	Threaded bush		C 45 N	1.0503	≤ DN 50, nitrided	-
			Multi-alloy bronze	-	≥ DN 65	-
902.1/2	Stud		21 CrMo V 5-7	1.7709	Corrosion-protected	-
920.1/2	Hexagon nut		25 CrMo 4	1.7218	Corrosion-protected	-
961	Handwheel	EN-GJS-400-15	5.3106	≤ DN 50	-	
		EN-GJL-250	5.1301	≥ DN 65	-	

² Recommended spare parts

Variants

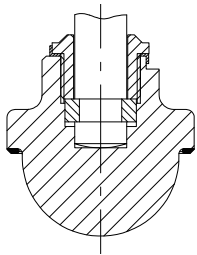

Throttling plug
DN 65 - 200

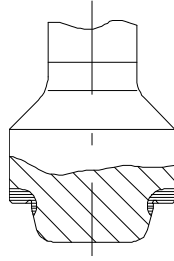

Single-piece stem and
throttling plug assembly
DN 10 - 50

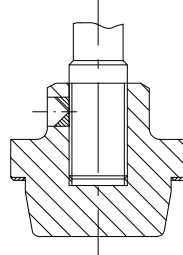

Single-piece stem and
throttling plug assembly
DN 65 - 200

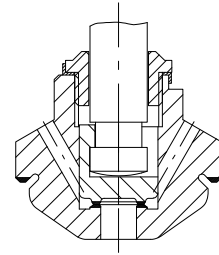

Balanced plug
DN 65 - 200

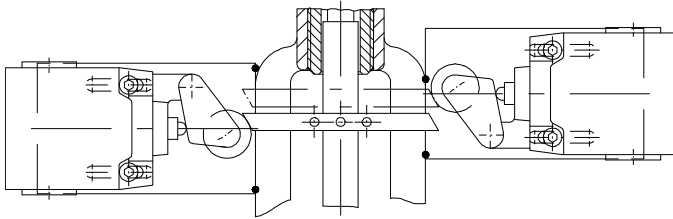

Limit switches DN 10 - 50

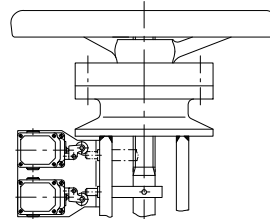

Limit switches DN 65 - 200

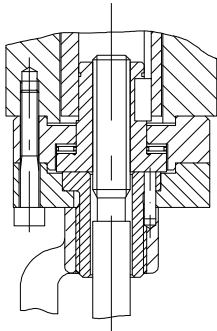

Mounting of electric actuators
DN 10 - 50

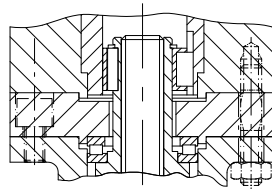

Mounting of electric actuators
DN 65 - 200

Dimensions and weights

Dimensions and weights of NORI 160 ZXLF

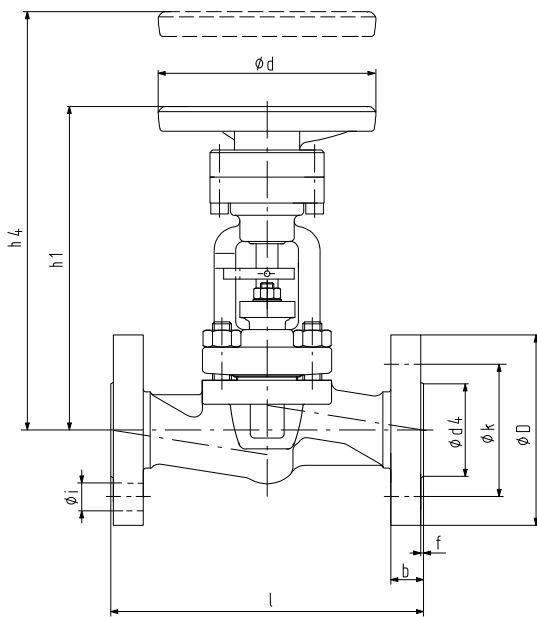

Fig. 2: NORI 160 ZXLF

Table 8: Dimensions and weights

PN	DN	l	ø D	ø k	No. of bolt holes z	Bolt hole dia. i	ø d ₄ × f	b	h ₁ ³⁾	h ₄ ⁴⁾	Travel	ø d	[kg]
		[mm]	[mm]	[mm]		[mm]							
63-160	10	210	100	70	4	14	40 × 2	20	240	280	11	160	11,5
	15	210	105	75	4	14	45 × 2	20	240	280	11	160	13,0
	20	230	130	90	4	18	58 × 2	24	240	280	11	160	14,5
	25	230	140	100	4	18	68 × 2	24	240	280	11	160	16,0
	32	260	155	110	4	22	78 × 2	26	310	360	17	200	20,0
	40	260	170	125	4	22	88 × 3	28	310	360	17	200	24,0
63	50	300	180	135	4	22	102 × 3	26	315	370	22	200	28,5
100/160	50	300	195	145	4	26	102 × 3	30	315	370	22	200	29,5
63	65	340	205	160	8	22	122 × 3	26	500	650	25	315	50,0
	80	380	215	170	8	22	138 × 3	28	575	730	42	500	72,0
	100	430	250	200	8	26	162 × 3	30	620	790	50	500	118,0
	125	500	295	240	8	30	188 × 3	34	670	860	63	500	162,0
	150	550	345	280	8	33	218 × 3	36	730	950	70	630	238,0
	200	650	415	345	12	36	285 × 3	42	830	1080	100	800	370,0
100	65	340	220	170	8	26	122 × 3	34	500	650	25	315	60,0
	80	380	230	180	8	26	138 × 3	36	575	730	42	500	82,0
	100	430	265	210	8	30	162 × 3	40	620	790	50	500	128,0
	125	500	315	250	8	33	188 × 3	40	670	860	63	500	175,0
	150	550	355	290	12	33	218 × 3	44	730	950	70	630	256,0
	200	650	430	360	12	36	285 × 3	52	830	1080	100	800	418,0
160	65	340	220	170	8	26	122 × 3	34	500	650	25	315	60,0
	80	380	230	180	8	26	138 × 3	36	575	730	42	500	82,0
	100	430	265	210	8	30	162 × 3	40	620	790	50	500	128,0
	125	500	315	250	8	33	188 × 3	44	670	860	63	500	178,0
	150	550	355	290	12	33	218 × 3	50	730	950	70	630	260,0
	200	650	430	360	12	36	285 × 3	60	830	1080	100	800	428,0

7633.1/23-EN

³ Open

⁴ Vertical clearance for removal

Mating dimensions as per standard

Face-to-face lengths: EN 558-1/2
Flanges: Mating dimensions to DIN EN 1092-1
Flange facing: Type B

Other flange designs

- E.g. groove (type D), recess (type F) to EN 1092-1 or lens gasket (type L) to DIN 2696 at both ends
- Other flange designs on request

Dimensions and weights of NORI 160 ZXSF

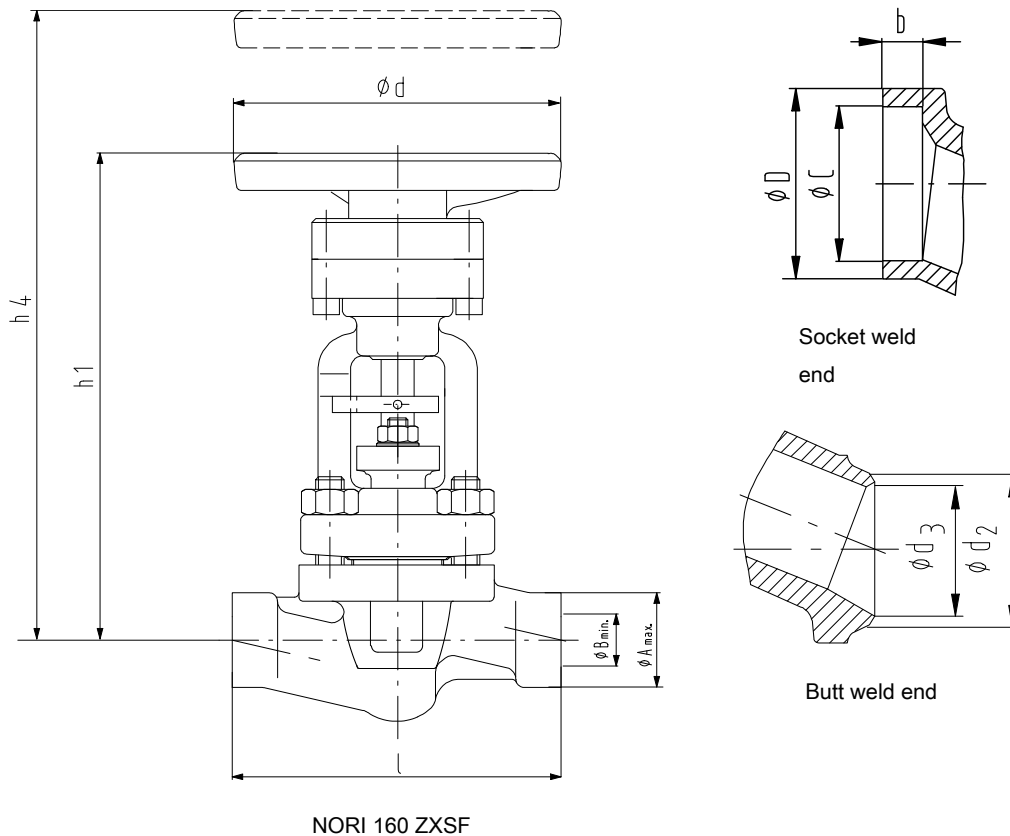

Table 9: Dimensions and weights

PN	DN	l	Butt weld ends, unmachined			Butt weld ends to DIN EN 12627			Associated pipe dimensions			Socket weld ends to DIN EN 12760			h ₁ ⁵⁾	h ₄ ⁶⁾	Trave l	ø d	[kg]
			ø A _{max.}	ø B _{min.}	ø d ₂	ø d ₃			PN 63	PN 100	PN 160	ø D _{-0,5}	ø C ^{+0,2}	b _{min.}					
						PN 63	PN 100	PN 160											
			[mm]	[mm]	[mm]	[mm]	[mm]	[mm]	[mm]	[mm]	[mm]	[mm]	[mm]	[mm]					
63 - 160	10	150	46	9	18	13,0	13,0	13,0	17,2 × 2,0	17,2 × 2,0	17,2 × 2,0	25,0	17,6	10	240	280	11	160	6,0
	15	150	46	14	22	17,0	17,0	17,0	21,3 × 2,0	21,3 × 2,0	21,3 × 2,0	30,5	21,7	10	240	280	11	160	6,5
	20	150	46	19	28	22,0	22,0	22,0	26,9 × 2,3	26,9 × 2,3	26,9 × 2,3	36,5	27,1	13	240	280	11	160	7,5
	25	160	46	22	34	28,5	28,5	27,0	33,7 × 2,6	33,7 × 2,6	33,7 × 3,2	44,5	33,8	13	240	280	11	160	8,5
	32	180	63	28	43	37,0	37,0	35,0	42,4 × 2,6	42,4 × 2,6	42,4 × 3,6	53,5	42,5	13	305	355	17	200	11,0
	40	210	63	35	49	43,0	43,0	41,0	48,3 × 2,6	48,3 × 2,6	48,3 × 3,6	60,5	48,7	13	305	355	17	200	13,5
	50	250	80	42	61	54,0	54,0	52,5	60,3 × 3,2	60,3 × 3,2	60,3 × 4,0	73,5	61,1	16	310	365	22	200	17,0
	65	420	83	52	77	69,0	69,0	65,0	76,1 × 3,6	76,1 × 3,6	76,1 × 5,6	-	-	-	500	650	25	315	30,0
	80	460	108	62	90	81,0	81,0	76,5	88,9 × 4,0	88,9 × 4,0	88,9 × 6,3	-	-	-	575	730	42	500	45,0
	100	510	118	78	115	104,0	104,0	98,5	114,3 × 5,0	114,3 × 5,0	114,3 × 8,0	-	-	-	620	790	50	500	72,0
	125	600	153	109	141	130,5	127,0	120,5	139,7 × 4,5	139,7 × 6,3	139,7 × 10,0	-	-	-	670	860	63	500	110,0
	150	650	173	125	170	156,5	154,0	144,5	168,3 × 5,6	168,3 × 7,1	168,3 × 12,5	-	-	-	730	950	70	630	165,0
200	750	229	176	222	204,5	199,5	189,0	219,1 × 7,1	219,1 × 10,0	219,1 × 16,0	-	-	-	830	1080	100	800	215,0	

Mating dimensions as per standard

Face-to-face lengths: EN 12982/65 (DN 10-50) and as per table (DN 65-200)

Butt weld ends: DIN EN 12627 Figure 2

Socket weld ends: DIN EN 12760

Different designs of butt weld ends, socket weld ends and welding groove types are possible, but only within the dimensions A_{max.} and B_{min.}.

Butt weld ends to DIN 3239/1 or socket weld ends to ASME B16.11 and DIN 3239/2 are possible.

⁵ Open

⁶ Vertical clearance for removal

Installation instructions

Shut-off globe valves must be installed in the line so as to ensure that the fluid enters the valve beneath the valve disc and flows out above the valve disc. They can also be installed in lines with alternating flow.

If the max. permissible differential pressures for shut-off are exceeded for valves from DN 65 to 200, a balanced plug design is required for handwheel-operated valves. In this case the valve must be installed in such a way that the pressure to be sealed off lies above the valve disc.

The balanced plug works on the bypass principle and can only serve its purpose if backpressure builds up after opening, so that the max. permissible differential pressures for shut-off (see table) are not exceeded.

Table 10: Differential pressure [bar] for manually operated valves with throttling plug or on/off disc

DN	Δp
65	110
80	70
100	44
125 ⁷⁾	33
150 ⁷⁾	21
200 ⁷⁾	14

Valves with single-piece stem and throttling plug assembly must be installed in such a way that the pressure to be sealed off lies above the plug.

For globe valves with throttling plug, detailed information about the operating mode is required for optimum valve selection.

⁷ Balanced plug design as standard



KSB SE & Co. KGaA
Bahnhofplatz 1 • 91257 Pegnitz (Germany)
Tel. +49 9241 71-0
www.ksb.com