

Vertical Turbine Pump

B Pump

Type Series Booklet



Legal information/Copyright

Type Series Booklet B Pump

All rights reserved. The contents provided herein must neither be distributed, copied, reproduced, edited or processed for any other purpose, nor otherwise transmitted, published or made available to a third party without the manufacturer's express written consent.

Subject to technical modification without prior notice.

© KSB Pumps Company Limited, Lahore, Pakistan 25/01/2021

Contents

Water Supply Pumps	4
Vertical Turbine Pump	4
B Pump	4
Main applications	4
Fluids handled	4
Operating data	4
Design details	4
Designation	5
Materials	5
Product benefits	6
Product information	6
Acceptance inspections/tests	6
Installation types	6
Selection charts	7
Characteristic curves	13
Dimensions and weights	40
Spare parts stock	44
Installation depths	46
General drawings with list of components	47

Water Supply Pumps

Vertical Turbine Pump

B Pump



Main applications

- Water supply systems
- Spray irrigation systems
- Lowering groundwater levels
- Drainage systems
- Seawater systems

Fluids handled

- Water
- Seawater
- Condensate

Operating data

Operating properties

Characteristic		Value
Flow rate	Q [m ³ /h]	≤ 2600
	Q [l/s]	≤ 722
Head	H [m]	≤ 260
Fluid temperature	T [°C]	≤ 105
Speed	n [rpm]	3500
Immersion depth	ET [m]	≤ 120
Borehole diameter	D [mm]	150 to 600
	D [inch]	6 to 24

Design details

Design

- Centrifugal pump
- Vertical installation
- Single-stage or multistage
- Pump shaft, intermediate shaft and top shaft connected via screwed coupling, conical coupling or split muff coupling
- Torque transmission from pump shaft to impeller and couplings via locking sleeves or keys
- Nominal discharge nozzle diameter: 80 mm - 500 mm
- Borehole diameter: 6 inches to 24 inches

Pump casing

- Radially split relative to the shaft
- Suction casing
- Discharge casing
- Pump bowl
- Replaceable casing wear rings

Impeller type

- Single-entry mixed flow impeller without hydraulic balancing
- Impeller wear rings (optional)
- Axially locked in position on the shaft via locking sleeves or stage sleeves

Shaft seal

- Gland packing
- Mechanical seal

Bearings

Shaft guide bearings:

- Product-lubricated plain bearings
- Pump shaft supported by bearing bush in each pump bowl
- Intermediate shaft supported by bearing spiders in bearing bushes installed between column pipes
- Model with shaft enclosing tube: column pipe bearings lubricated by external fluid (water /oil)

Thrust bearings:

- Grease-lubricated rolling element bearings
- Angular contact ball bearings in back-to-back arrangement
- Uncooled

Designation
Example: B10B / 7VN / V1

Designation key

Code	Description	
B	Type series	
10	Borehole size in inches	
B	Impeller type	
	B	$n_q \approx 54$
	D	$n_q \approx 74$
	F	$n_q \approx 82$
7	Number of stages of the hydraulic system	
VN	Installation type	
	VN	Vertical, standard Discharge nozzle flange arranged above-floor at the distributor casing
	VU	Vertical, underfloor Discharge nozzle flange arranged at column (shaft enclosing tube)
V1	Type of drive	
	V1	Direct drive by vertical electric motor

Materials

Overview of available materials Pump

Part No.	Description	Material variant					
		GG	GB	SS	BZ	Duplex 1.4517	Super duplex stainless steel 1.4469
106	Suction casing	EN-GJL-250	G CuSn10-C	1.4408	G CuSn10-C	1.4517	1.4469
107	Discharge casing	EN-GJL-250	G-CuSn10-C	1.4408	G-CuSn10-C	1.4517	1.4469
112	Pump bowl	EN-GJL-250	G-CuSn10-C	1.4408	G-CuSn10-C	1.4517	1.4469
211	Pump shaft	1.4021	1.4021	1.4401 / AISI 316	1.4401 / AISI 316	1.4462	1.4410
230	Impeller	EN-GJL-250	G-CuSn10-C	1.4408	G-CuSn10-C	1.4517	1.4469
502	Casing wear ring	EN-GJL-250	EN-GJL-250	1.4408	G-CuSn10-C	1.4517	1.4469
529	Bearing sleeve	G CuSn10-C	G-CuSn10-C	Rubber	Rubber	Rubber	Rubber
545	Bearing bush	Stainless steel, rubber-lined	Stainless steel, rubber-lined	Rubber	Rubber	Rubber	Rubber
840	Coupling	1.4021	1.4021	1.4401 / AISI 316	1.4401 / AISI 316	1.4462	1.4410
-	Fasteners	A4	A4	A4	A4	1.4462	1.4410

Overview of available materials Column pipe set

Part No.	Description	Material variant					
		Steel C45	Stainless steel 1.4021	Stainless steel 1.4401	Stainless steel 1.4462	Super duplex stainless steel 1.4469	
212	Intermediate shaft	C45	1.4021	1.4401	1.4462	1.4410	
213	Top shaft	C45	1.4021	1.4401	1.4462	1.4410	
383	Bearing spider	EN-GJL-250	EN-GJL-250	G-CuSn10-C	1.4517	1.4469	
524	Shaft protecting sleeve	Product-lubricated	1.4021	1.4021	1.4401 / AISI 316	1.4462	1.4410
		Grease-lubricated	1.4021	1.4021	1.4401 / AISI 316	1.4462	1.4410
545	Bearing bush	Product-lubricated	Stainless steel, rubber-lined	Stainless steel, rubber-lined	Thordon / Vesconite	Thordon / Vesconite	Thordon / Vesconite
		Grease-lubricated	G-CuSn10-C	G-CuSn10-C	G-CuSn10-C	G-CuSn10-C	G-CuSn10-C
851	Conical coupling	C45	1.4021	1.4401	1.4462	1.4410	
852	Screwed coupling	C45	1.4021	1.4401	1.4462	1.4410	
-	Fasteners	A2 ¹⁾	A4	A4	1.4462	1.4410	

¹ Property class 6.8

Product benefits

- Available with both above-floor discharge and underfloor discharge
- Available with or without shaft enclosing tube
- Shaft sealed by gland packing or mechanical seal
- Available with bearings cooled by the fluid handled
- Drive options: V1/VHS motor, gear unit, belt drive, diesel engine
- Various material variants available
- Available for angled installation
- Suitable for drinking water in acc. with NSF (not NSF-certified)

Product information

Product information as per Regulation No. 1907/2006 (REACH)

For information as per chemicals Regulation (EC) No 1907/2006 (REACH), see https://www.ksb.com/ksb-de/konzern/Unternehmerische_Verantwortung/reach/

Acceptance inspections/tests

Hydrostatic test

The test pressure is normally 1.5 times the operating pressure. The hydrostatic test is carried out using cold water.

Test standards

The test can be performed in accordance with ISO 9906 Class 2B (standard)²⁾.

Installation types

- **Wet installation**
The pump is fully submerged, or – for commissioning – submerged at least up to the first-stage impeller, in the fluid handled. The minimum submergence of the first-stage impeller must equal dimension B (minimum water level above the bottom edge of the suction casing). If the pump is equipped with a suction pipe and suction strainer, the liquid level can drop below the level of the first-stage impeller during operation. In this case make sure that the minimum liquid level is 1.0 × the nominal diameter of the suction casing above the top edge of the suction strainer to avoid air intake.
- **Dry installation**
The pump is not submerged in the fluid handled. The fluid handled is supplied to the first-stage impeller through a suction/inlet line. To prevent the pump from being pulled out of its vertical position, connect the inlet line to the suction casing via a special duckfoot bend. The minimum submergence is the same as for wet installation.

²⁾ ISO 9906 Class 2B supersedes the following standards: ANSI - Hydraulic Institute Standard, BS 5316 Parts 1 and 2, ISO 3555 Class B, ISO 2548 Class C, DIN 1944 / III, II, I (with negative tolerance).

Selection charts

B Pump, impeller type B, n = 2900 rpm

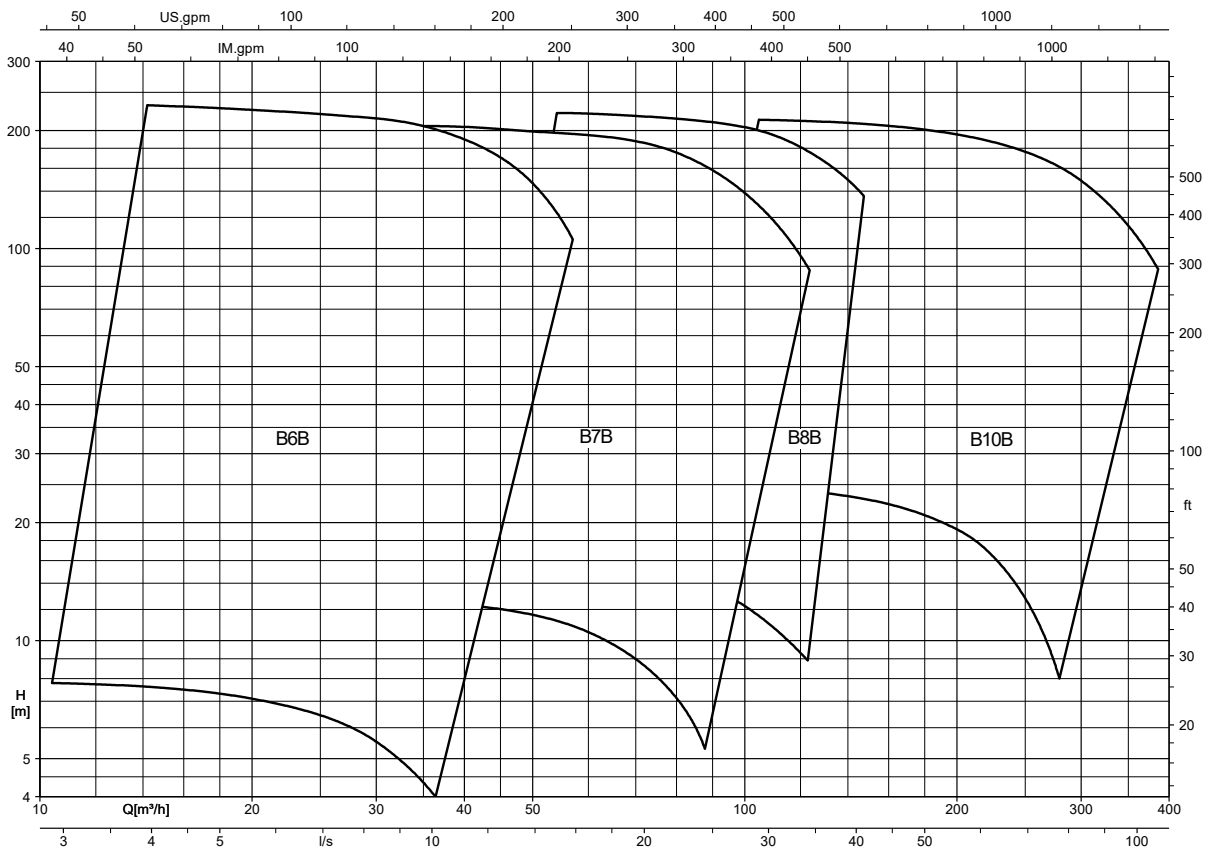

Raster_B Impeller@2900rpm / 1

B Pump, impeller type D, n = 2900 rpm

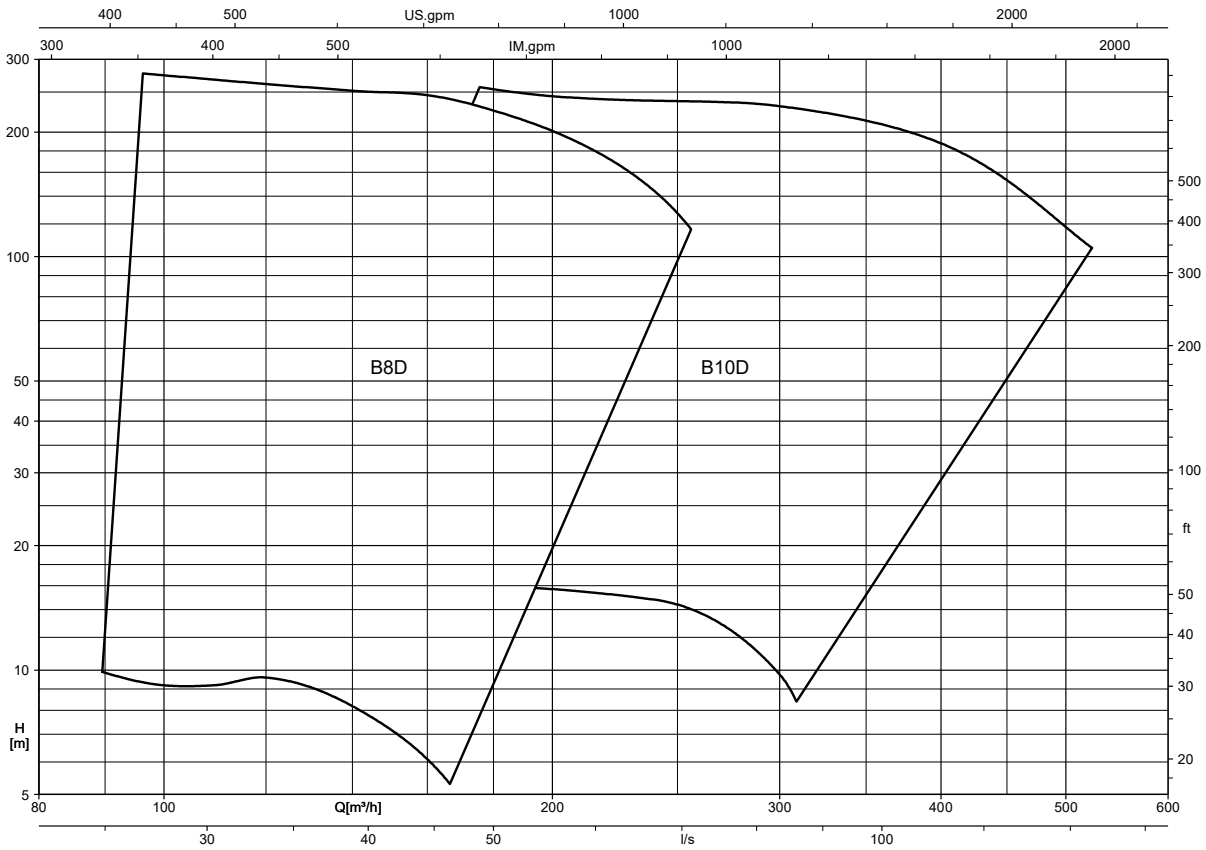

Raster_D impeller@2900rpm / 1

B Pump, impeller type B, n = 1450 rpm

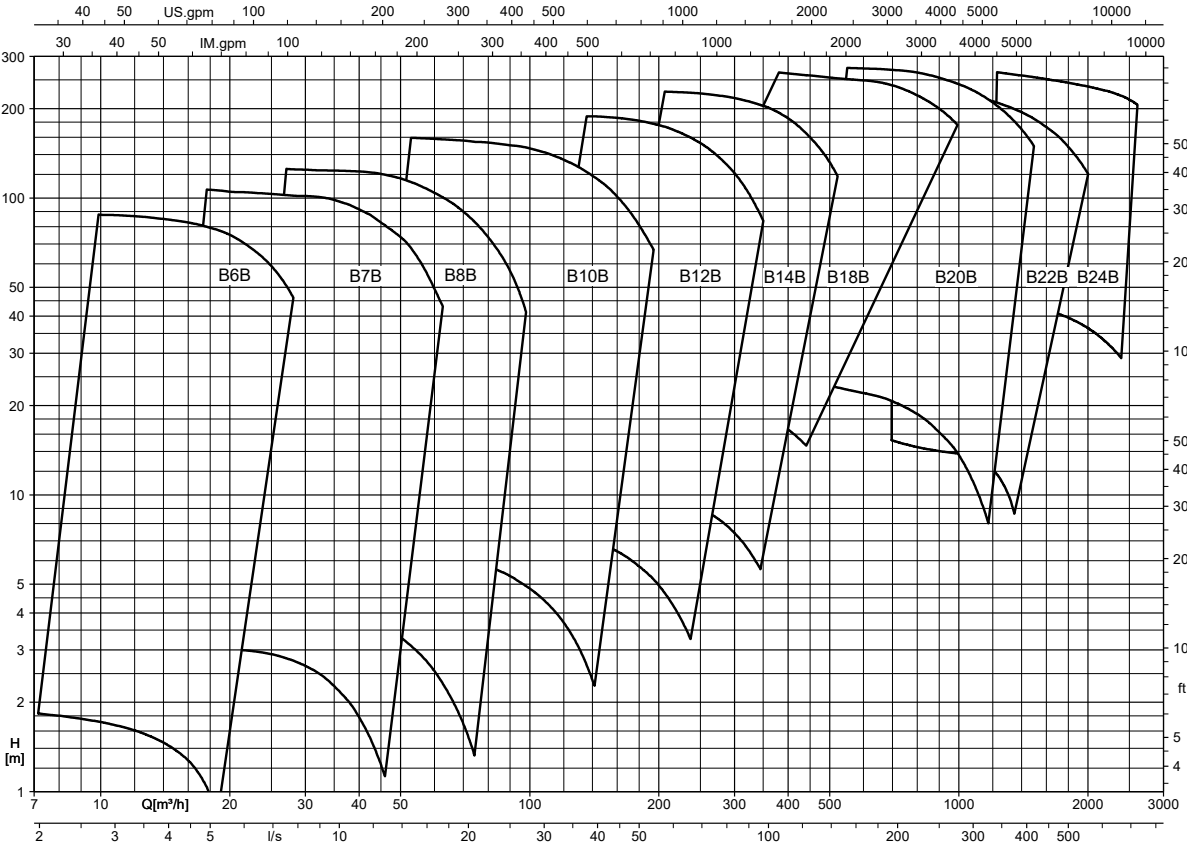

Raster_B Impeller @1450rpm / 1

B Pump, impeller type D, n = 1450 rpm

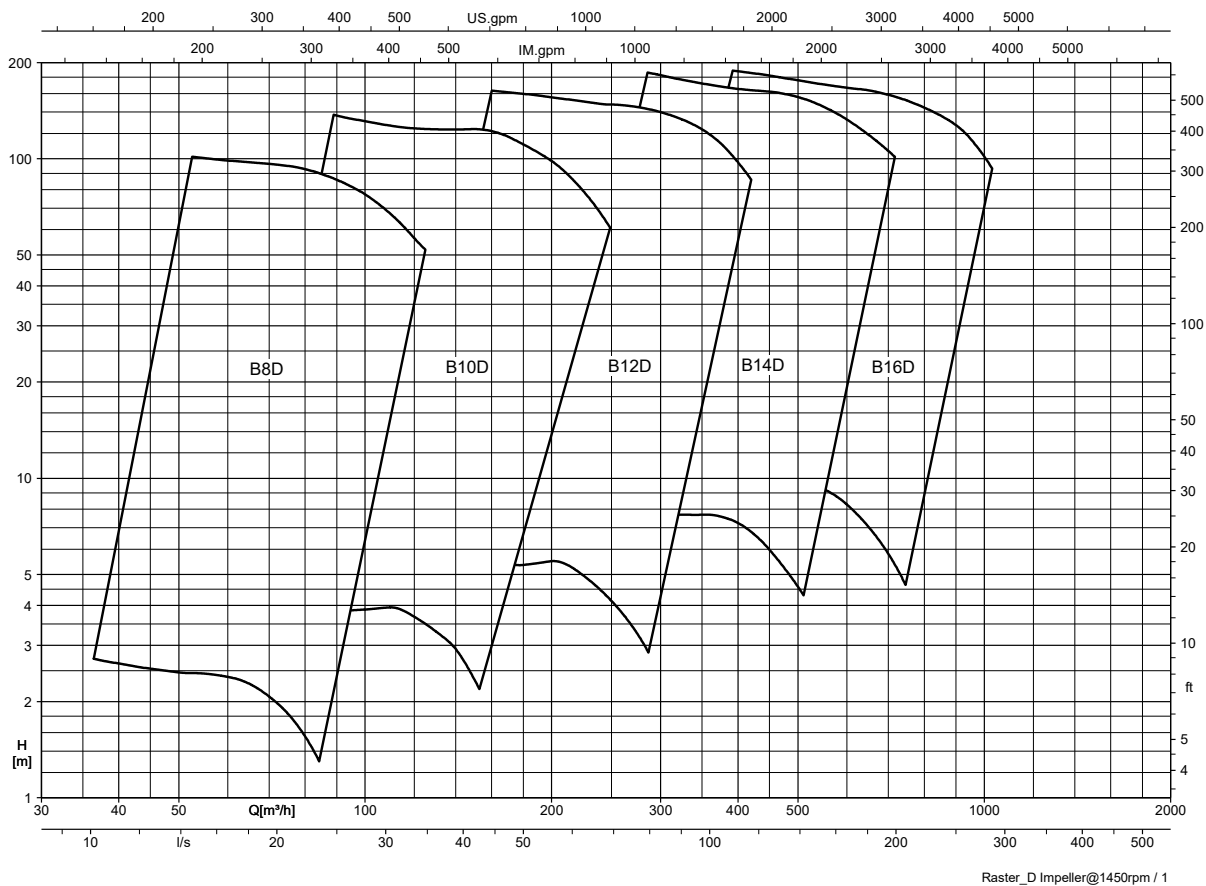

B Pump, impeller type F, n = 1450 rpm

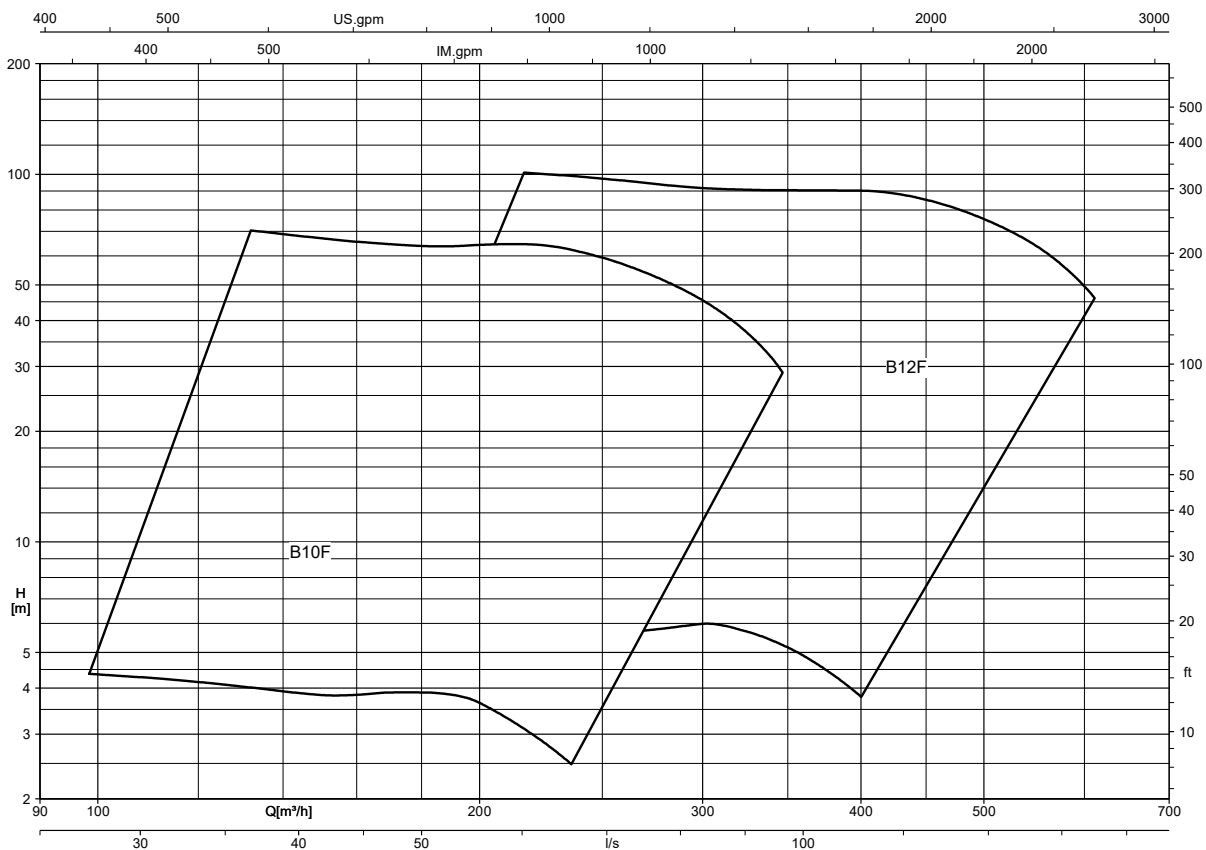

Raster_F Impeller @1450rpm / 1

B Pump, impeller type B, n = 980 rpm

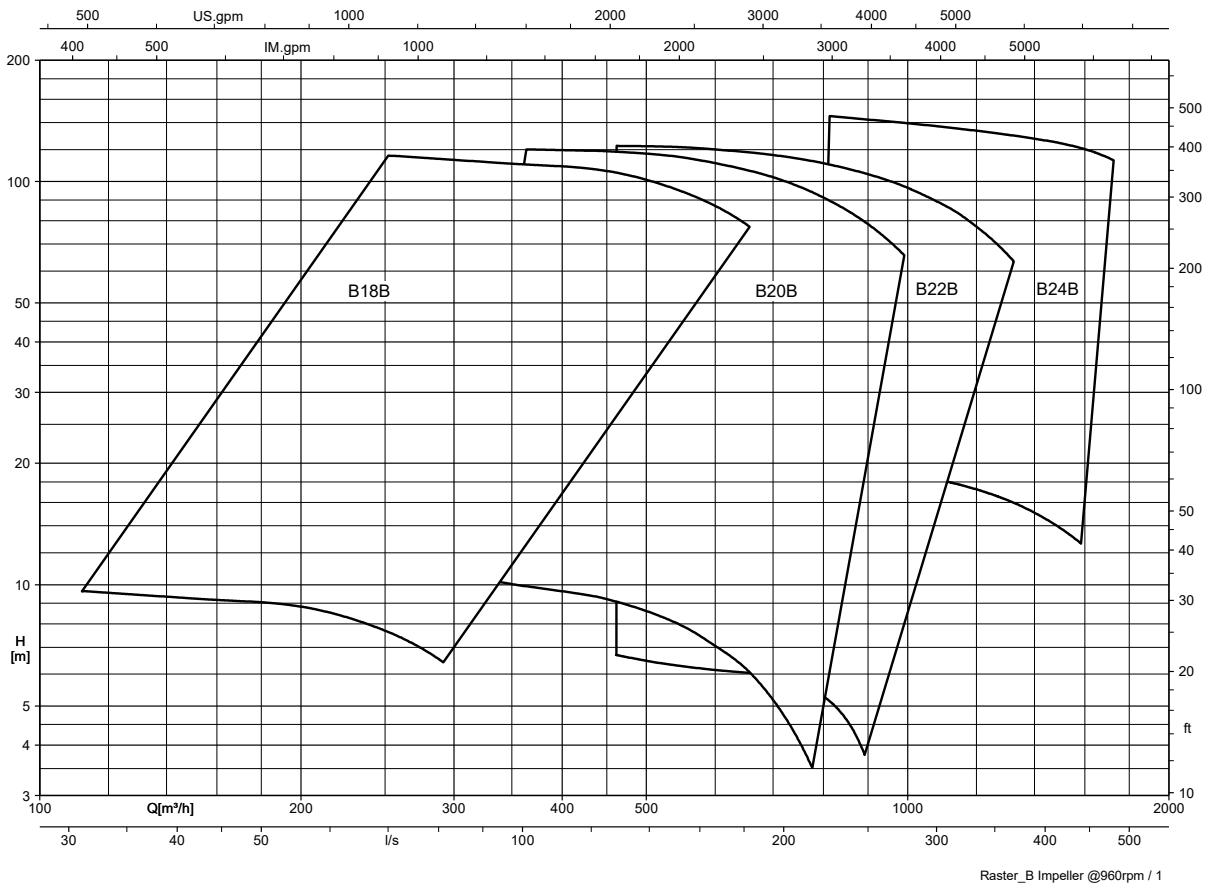

Characteristic curves

n = 2900 rpm

B6B, n = 2900 rpm

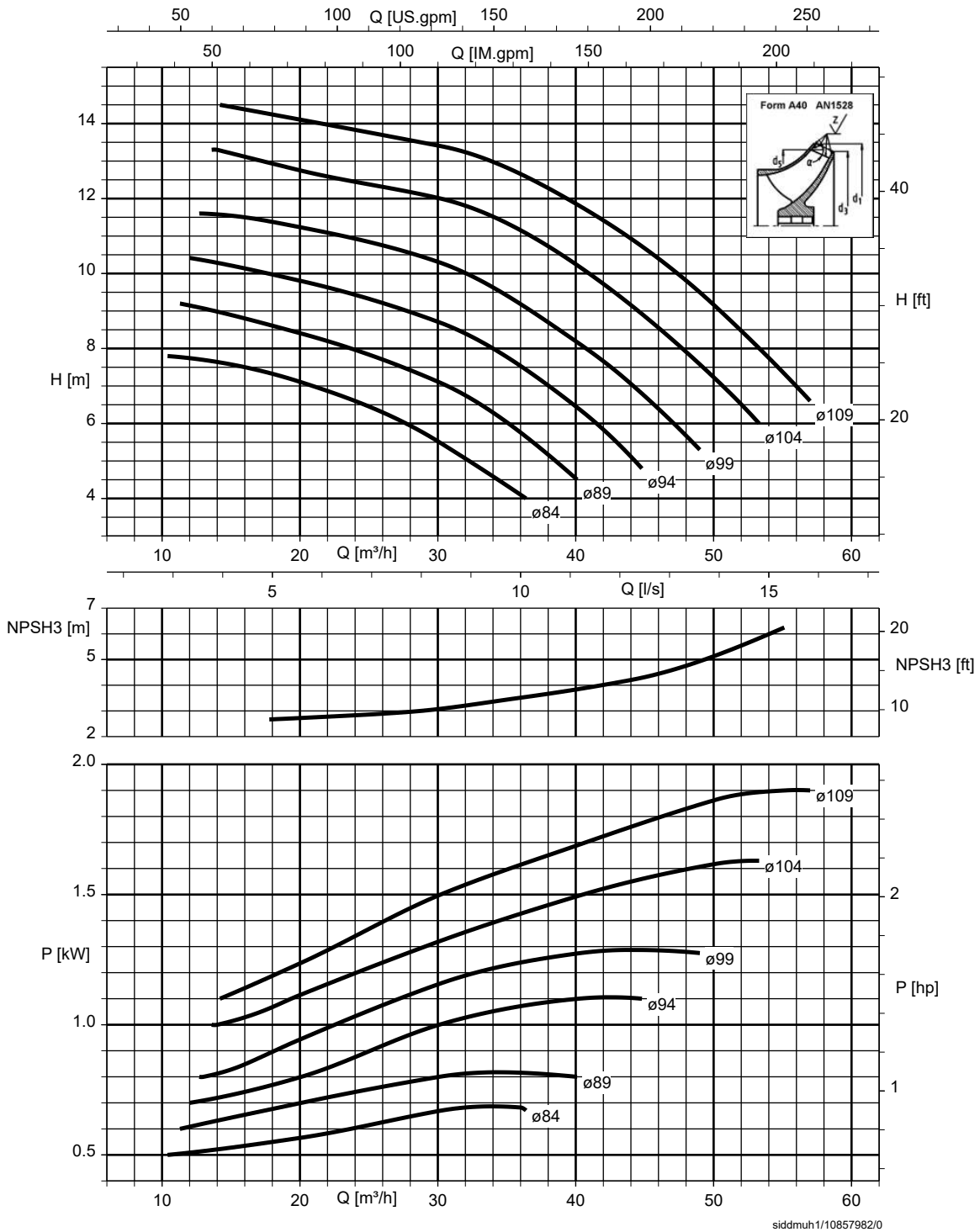

B7B, n = 2900 rpm

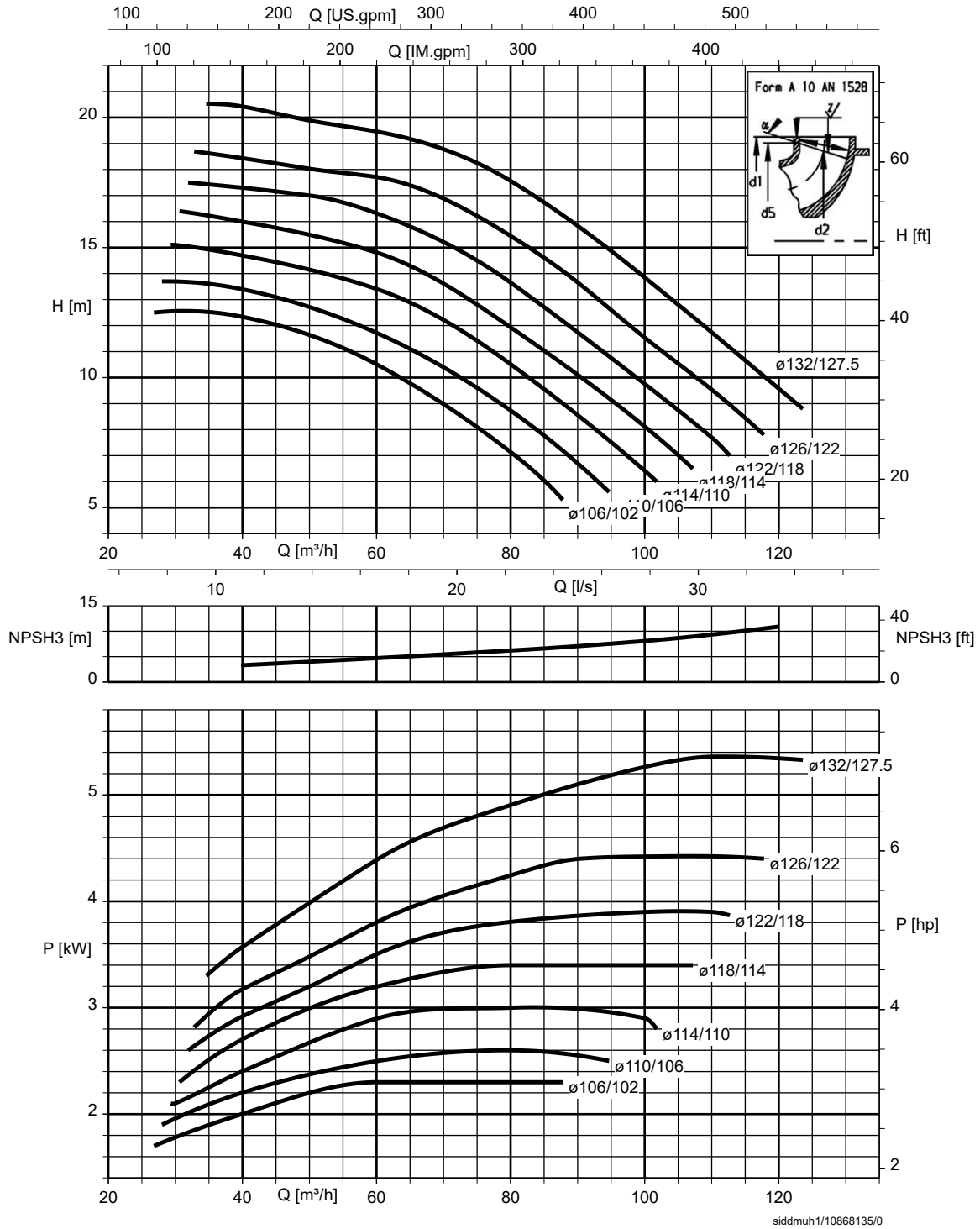

B8B, n = 2900 rpm

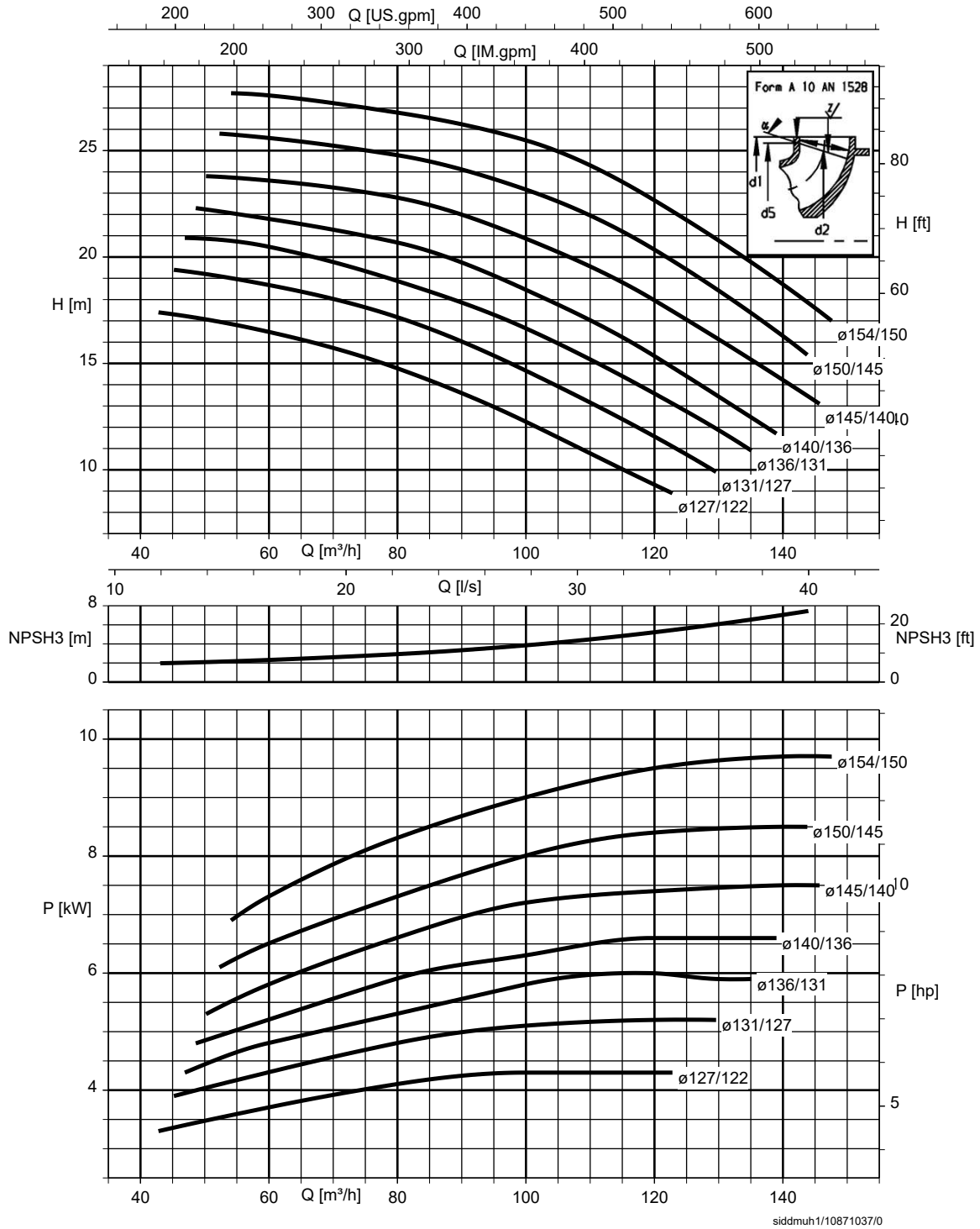

B8D, n = 2900 rpm

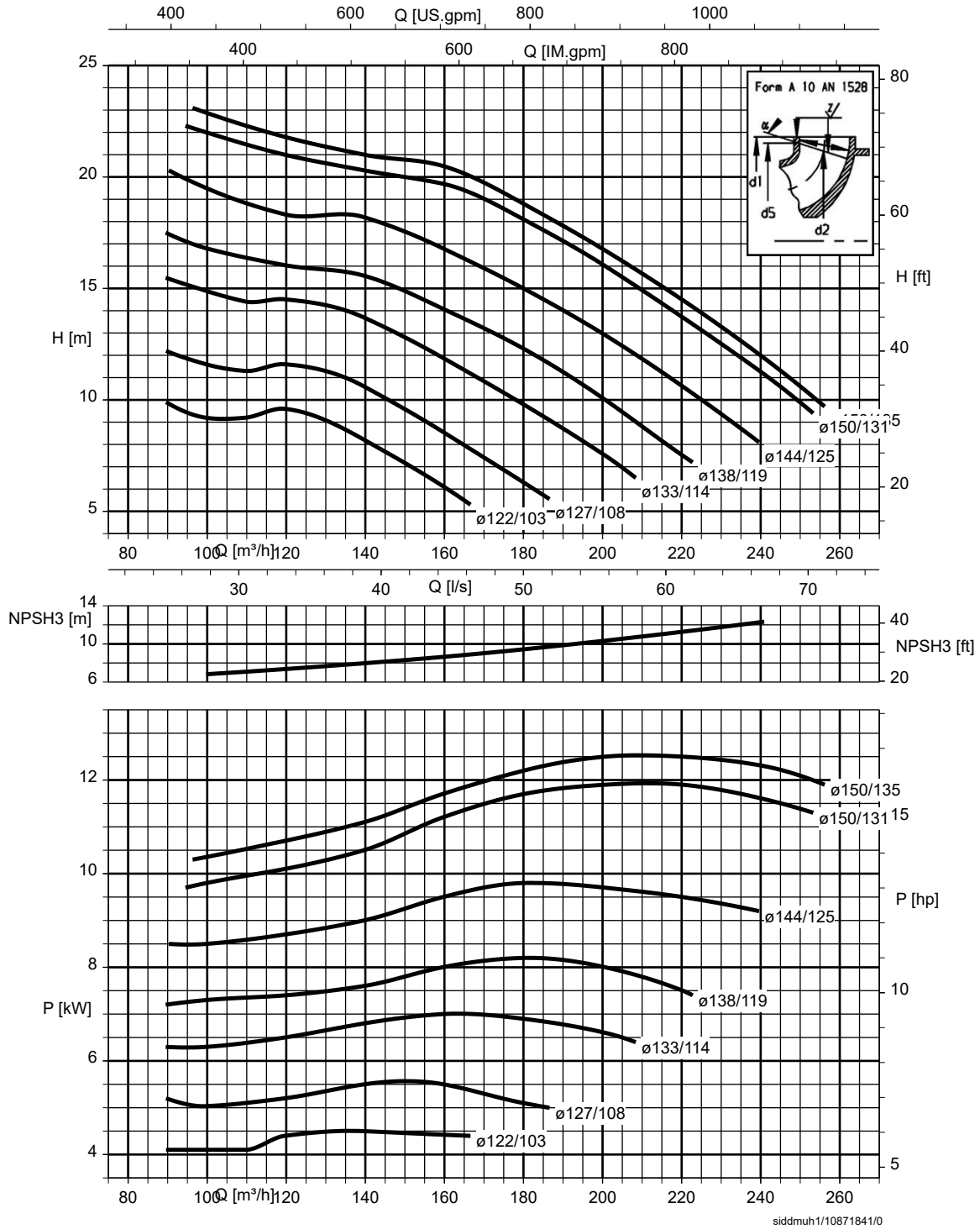

B10B, n = 2900 rpm

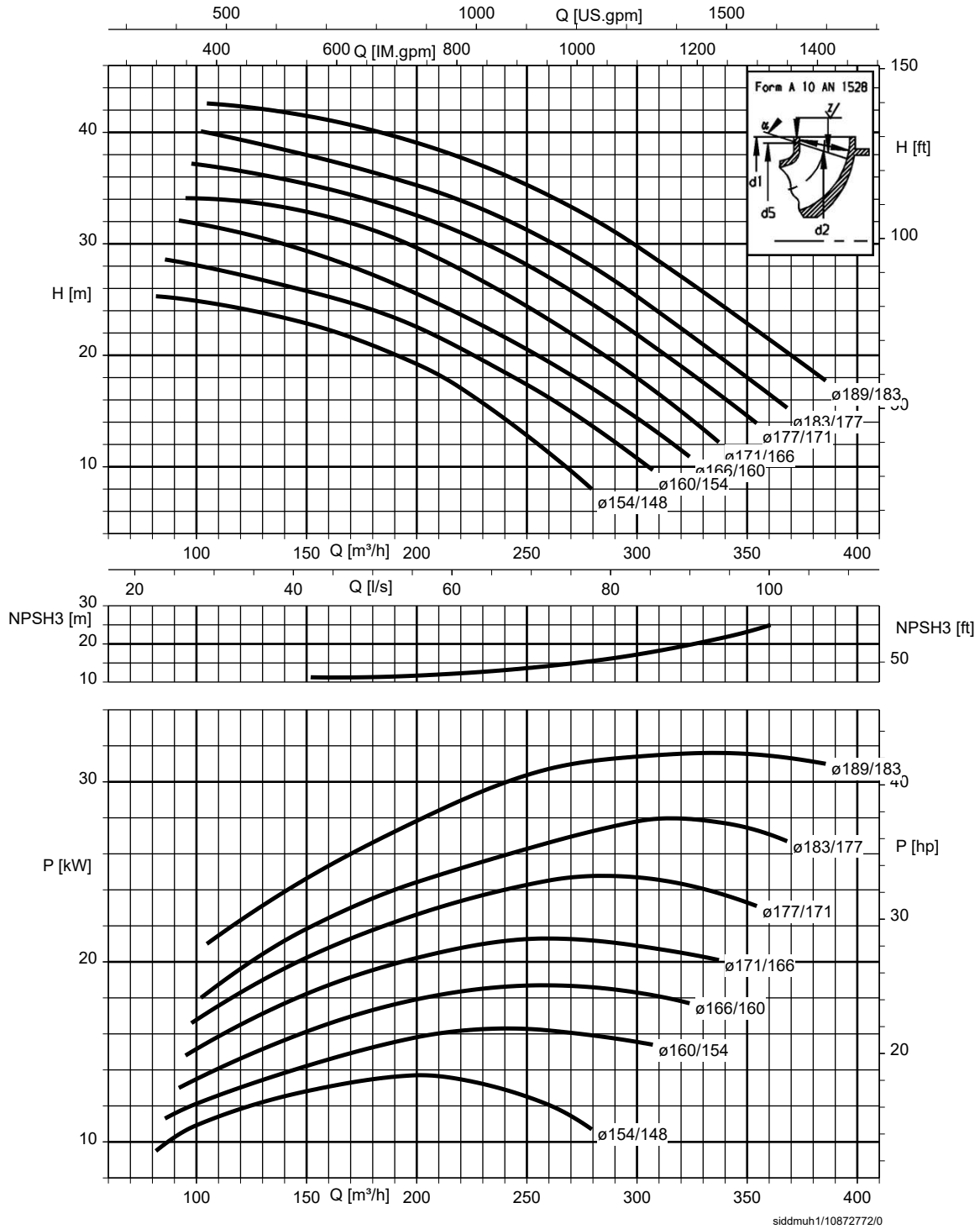

B10D, n = 2900 rpm

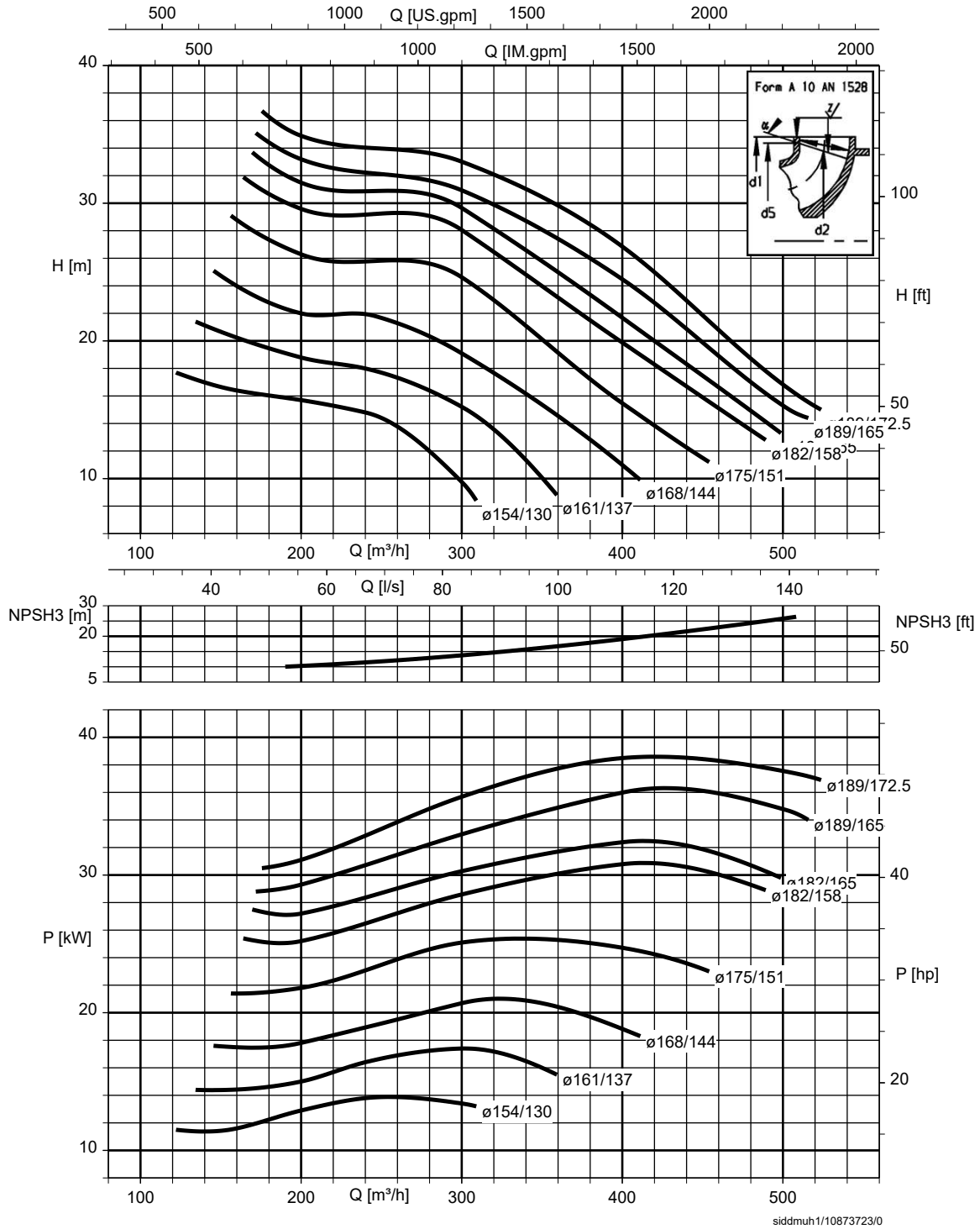

n = 1450 rpm

B6B, n = 1450 rpm

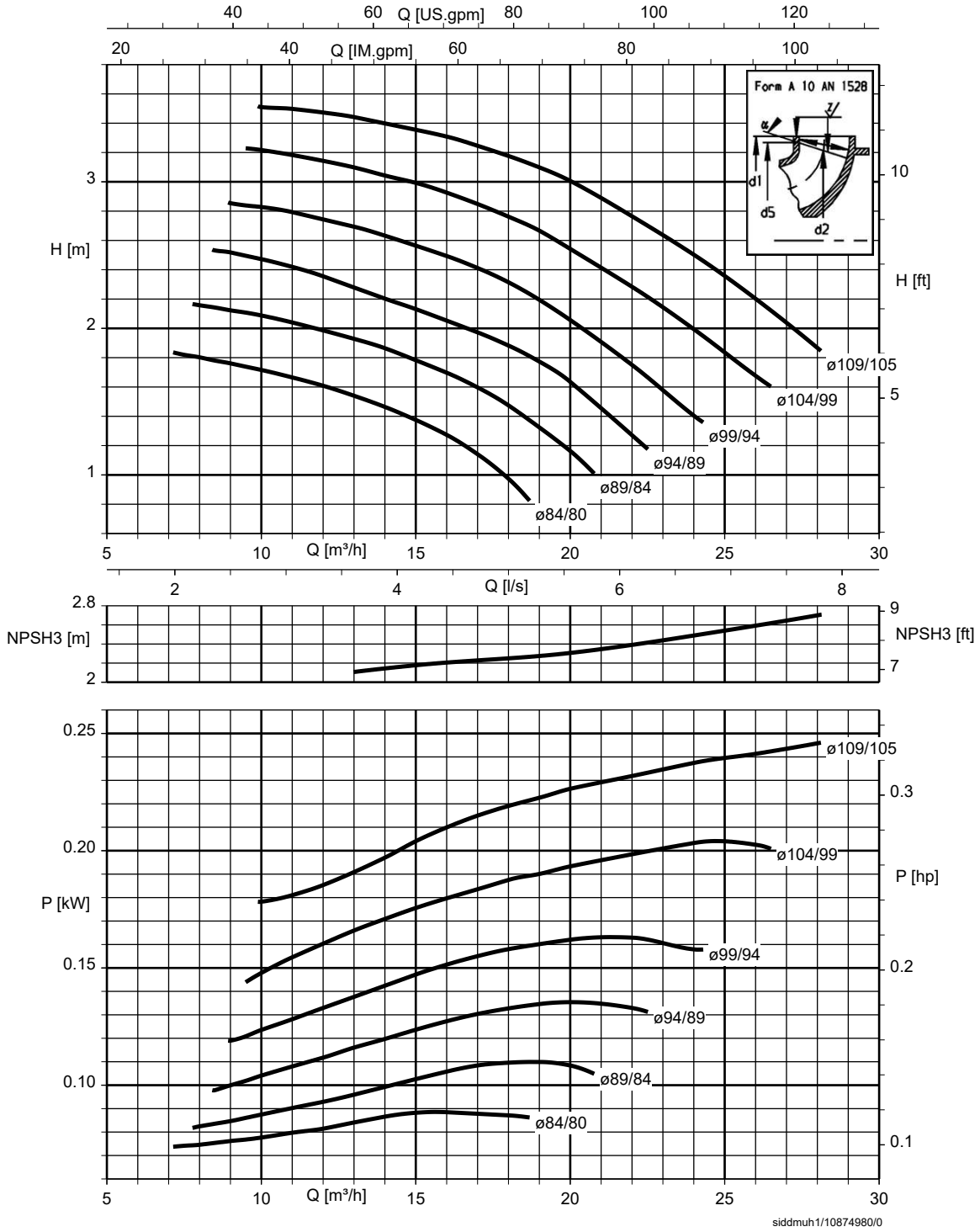

B7B, n = 1450 rpm

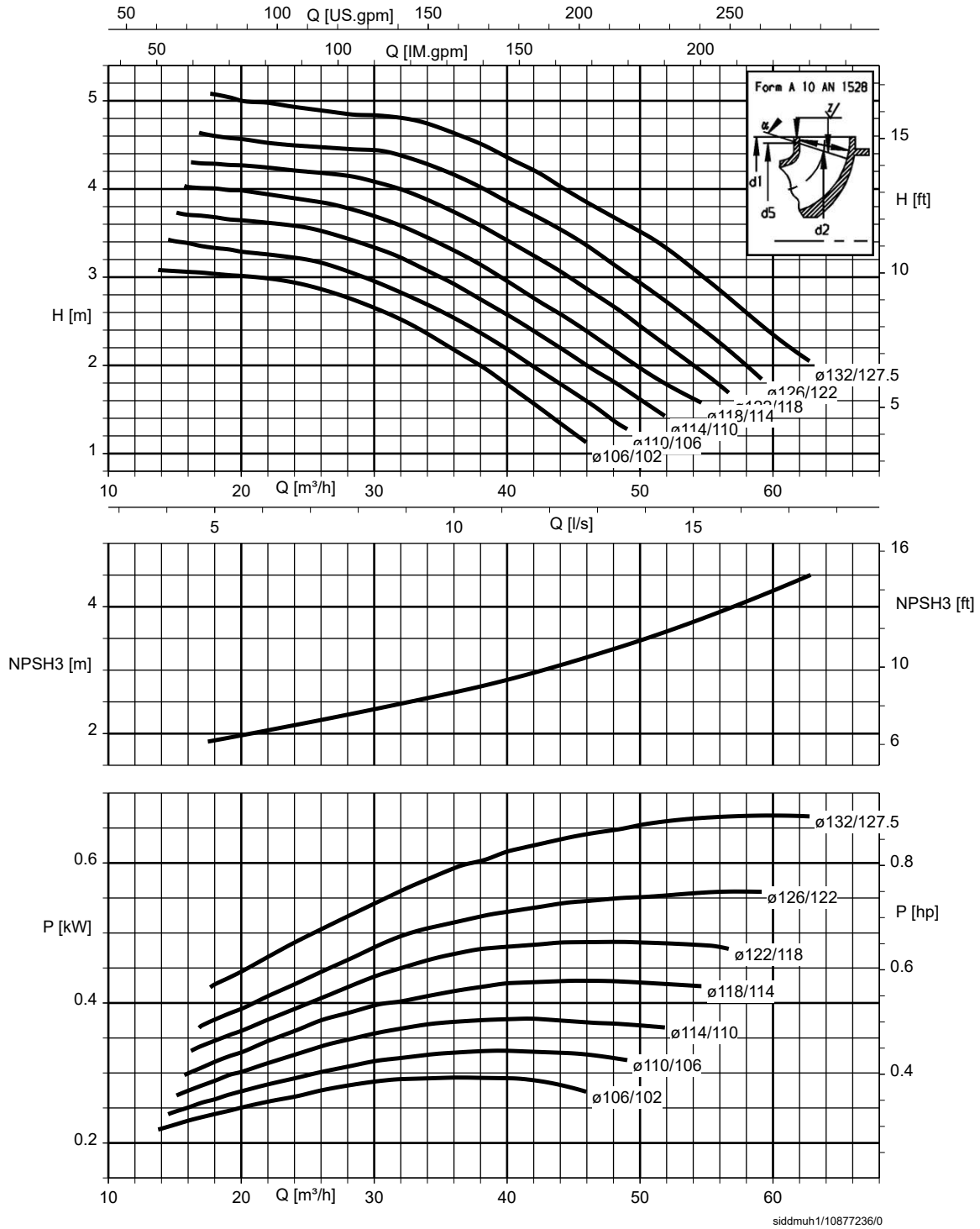

B8B, n = 1450 rpm

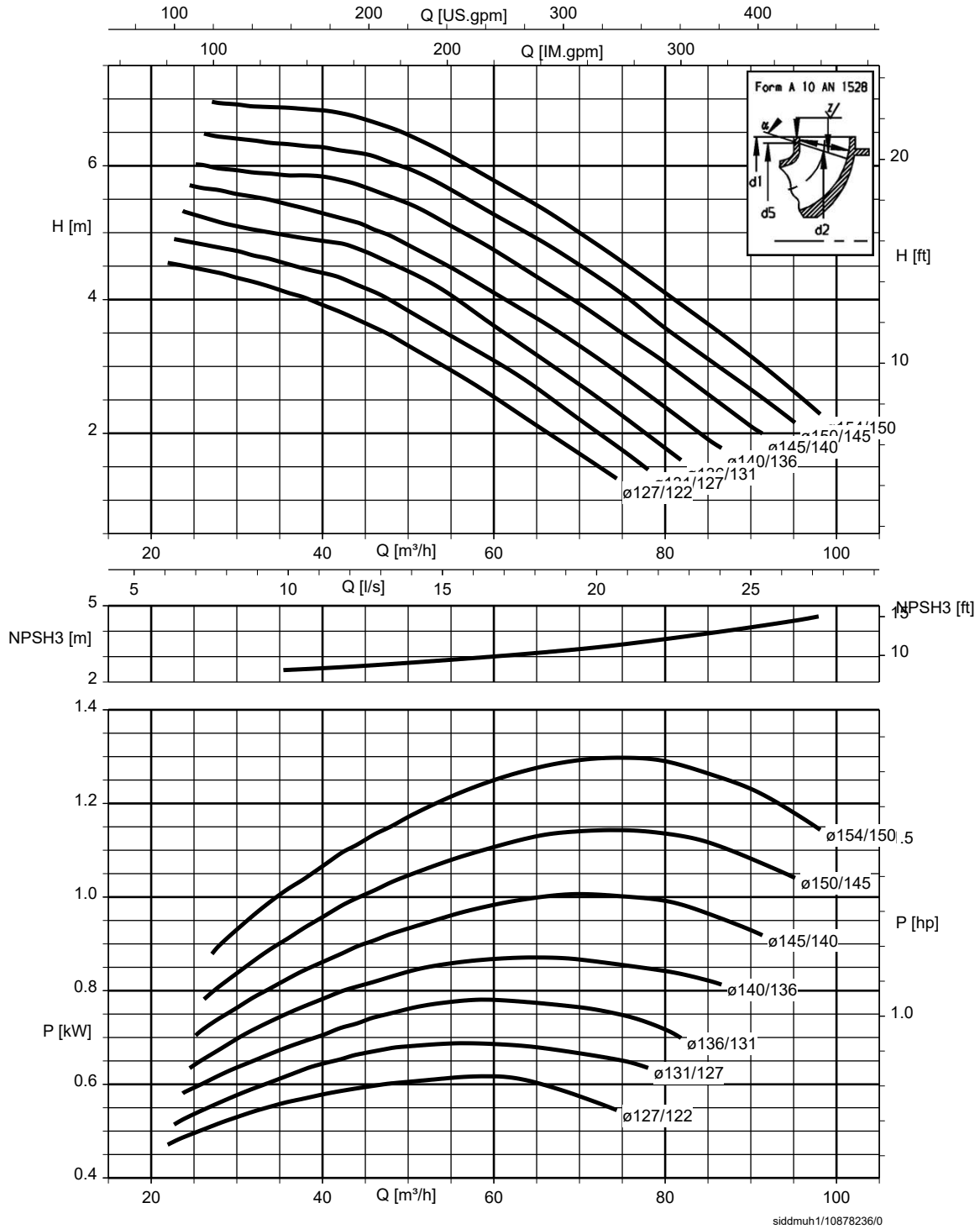

B8D, n = 1450 rpm

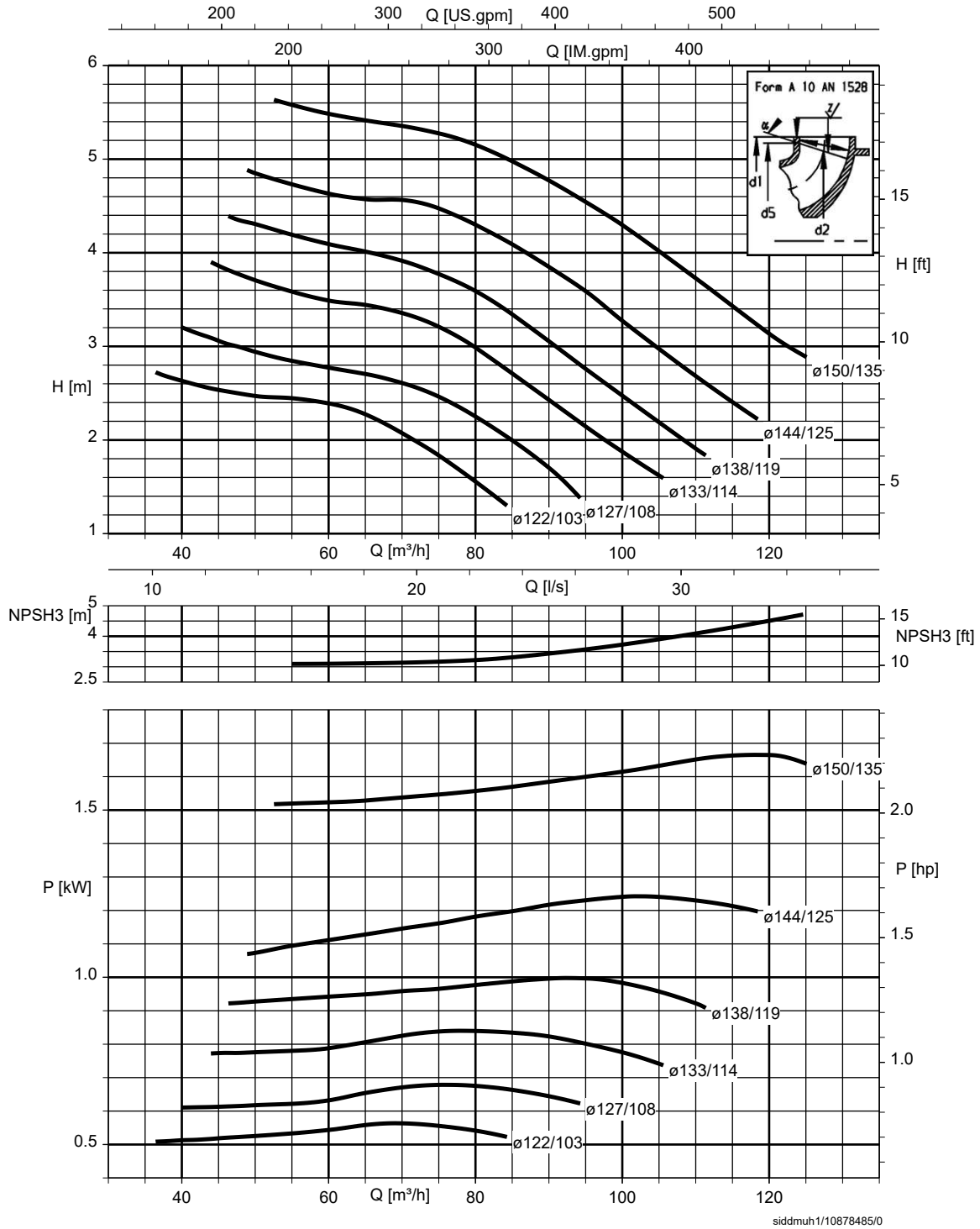

B10B, n = 1450 rpm

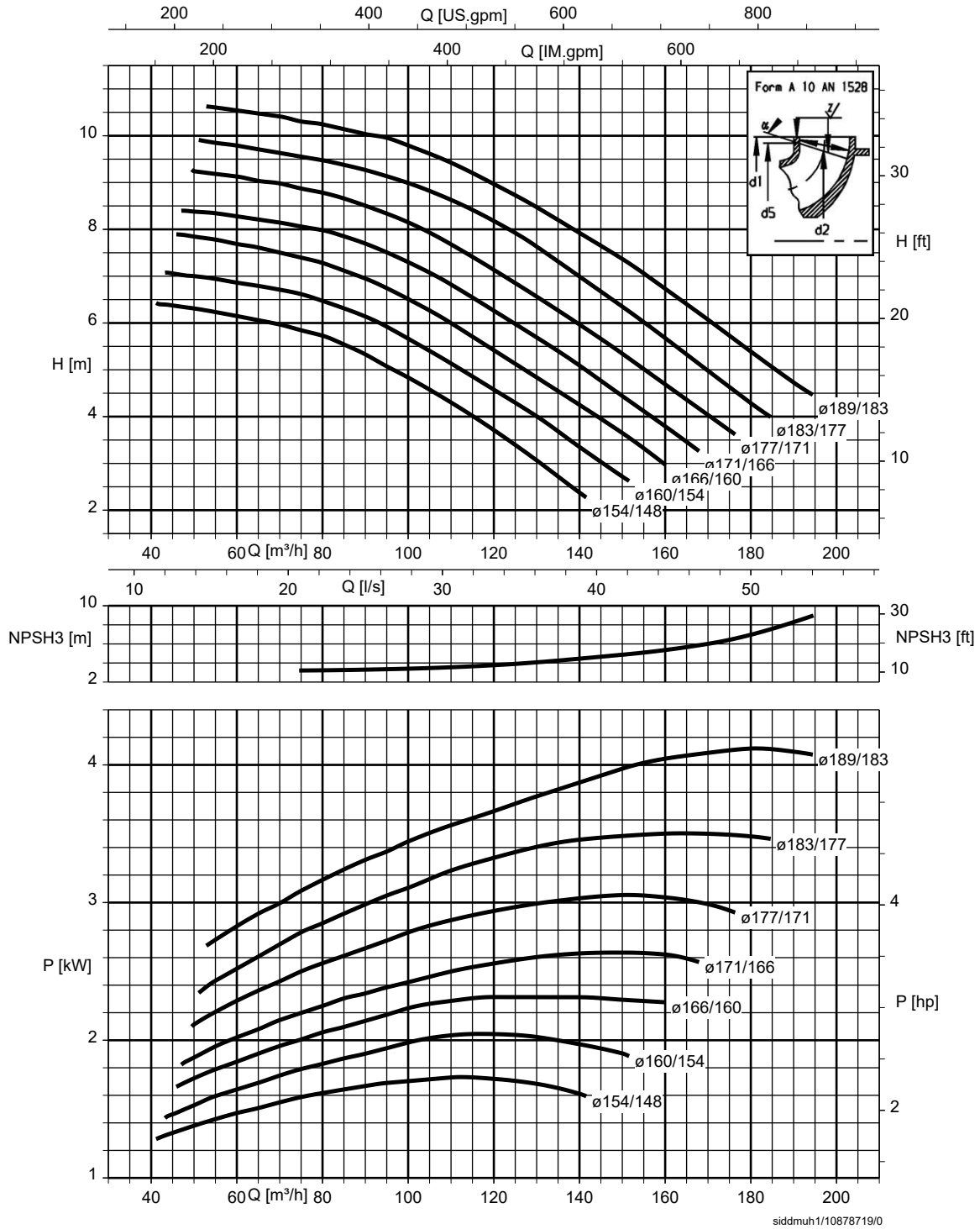

B10D, n = 1450 rpm

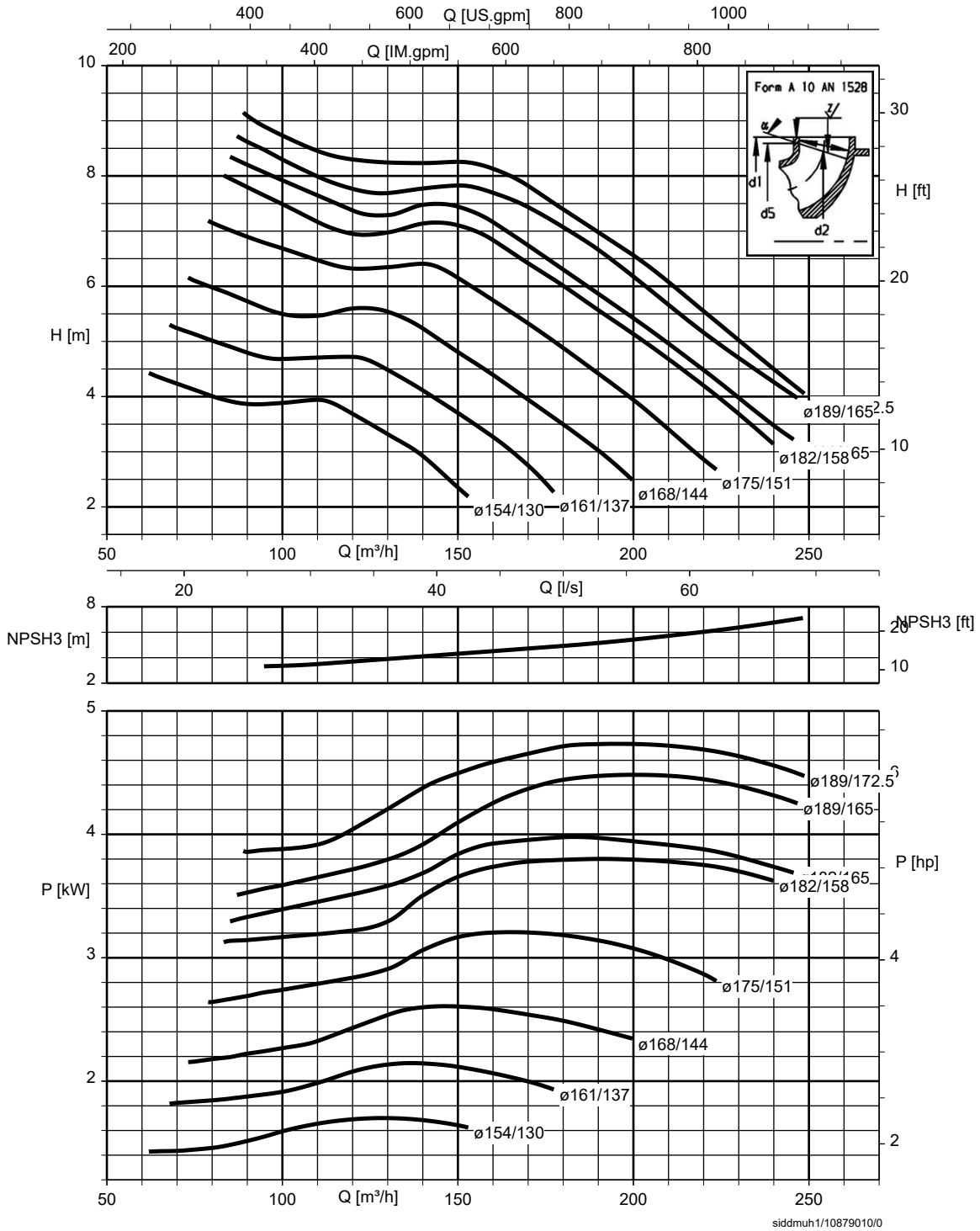

B10F, n = 1450 rpm

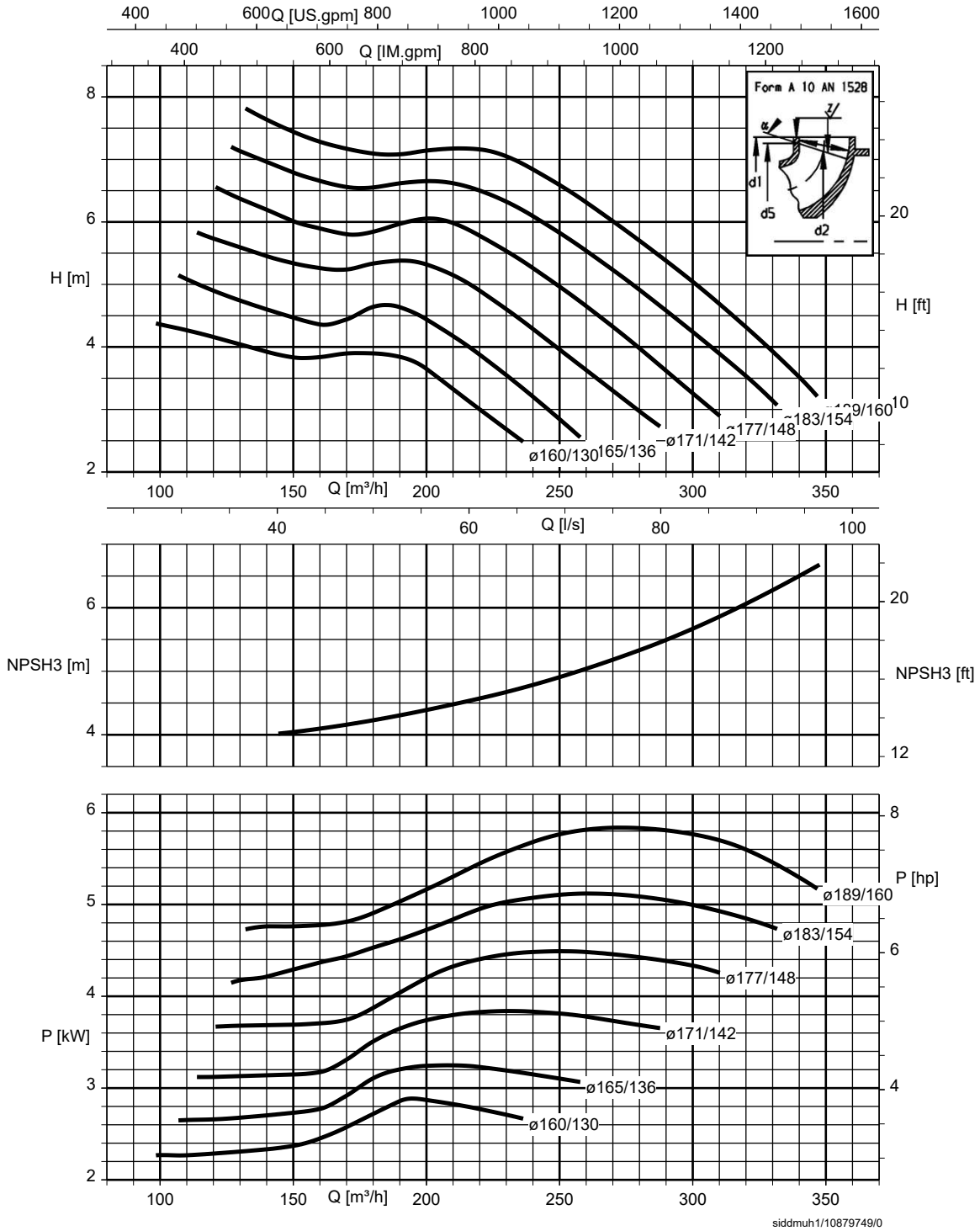

B12B, n = 1450 rpm

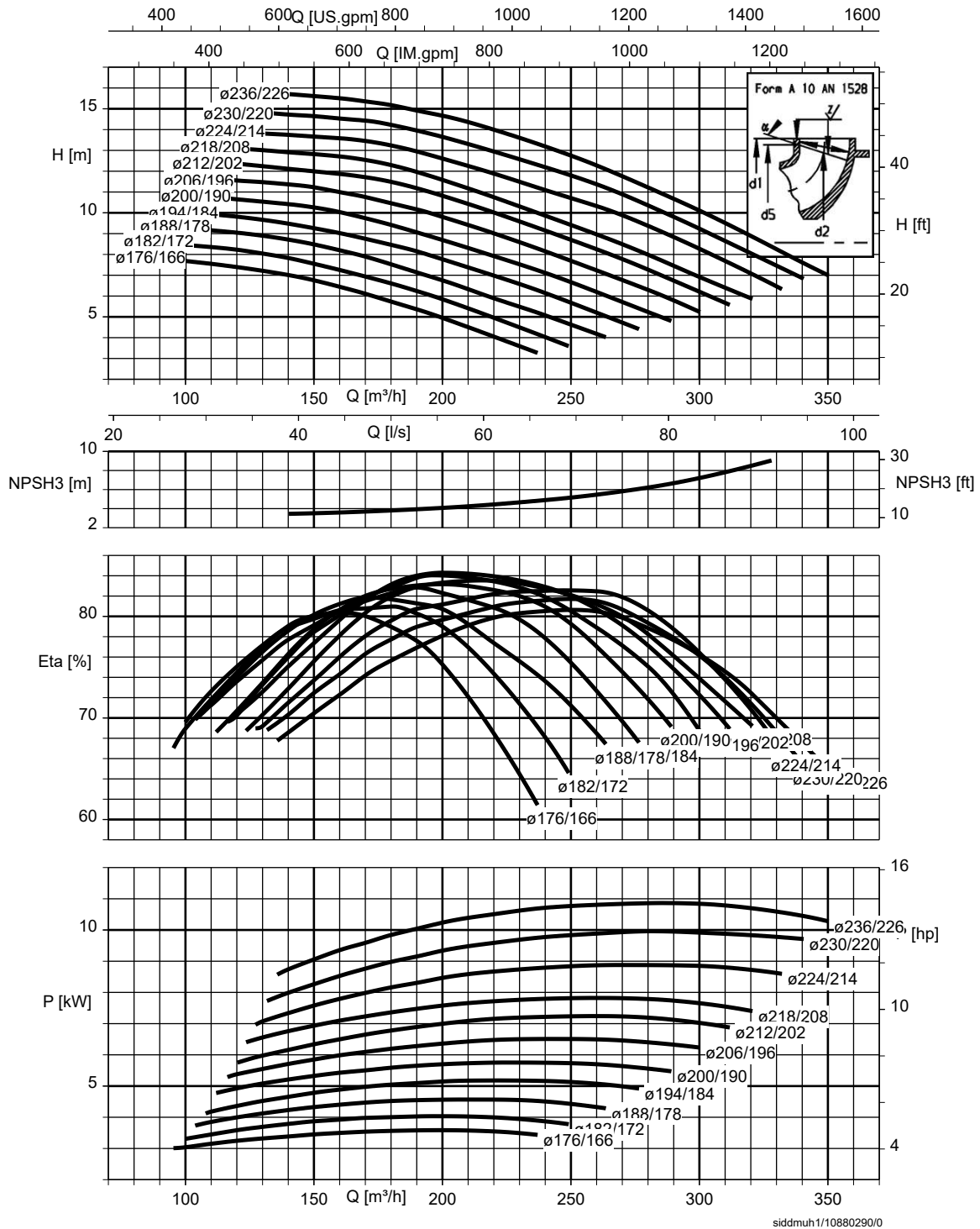

B12D, n = 1450 rpm

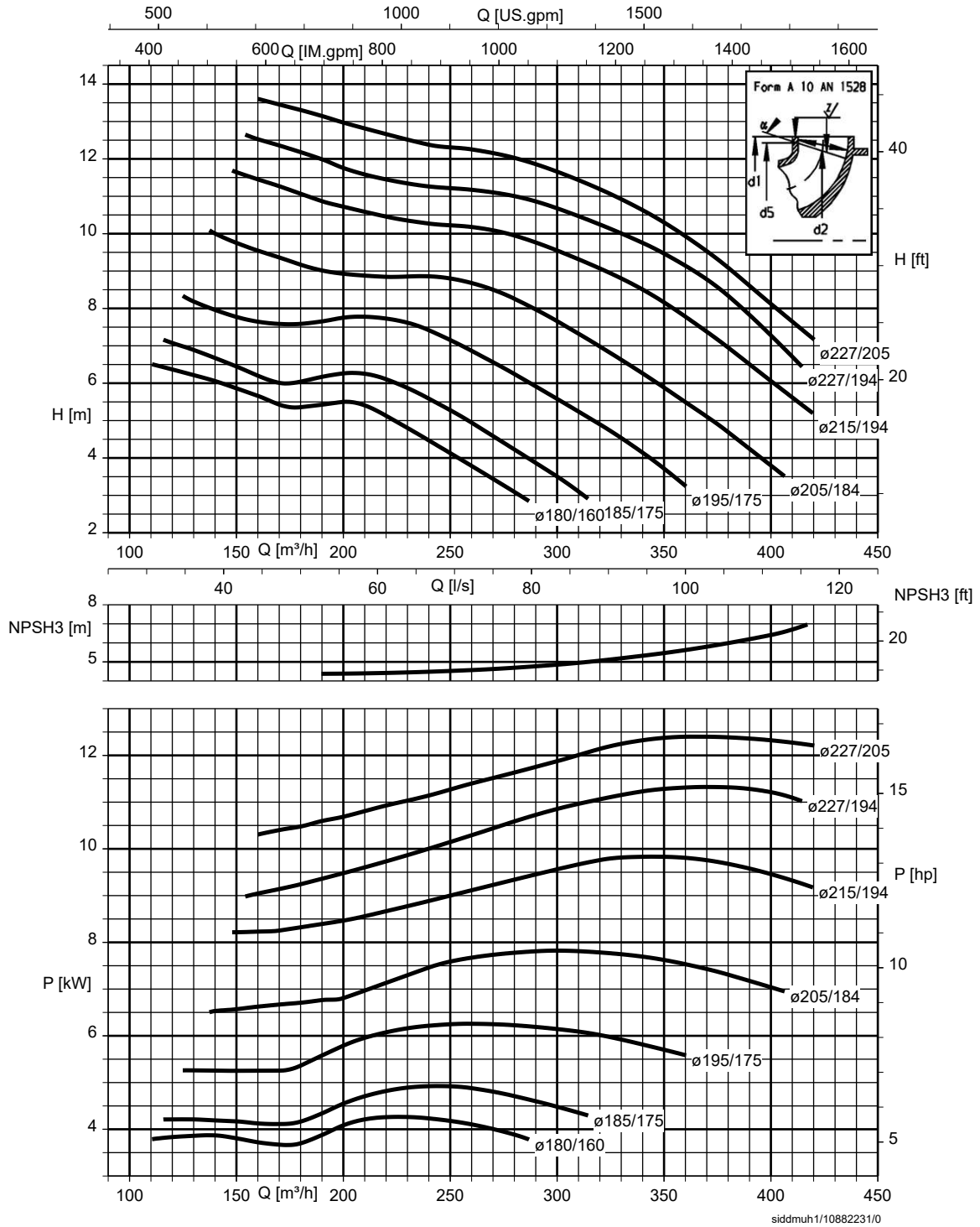

B12F, n = 1450 rpm

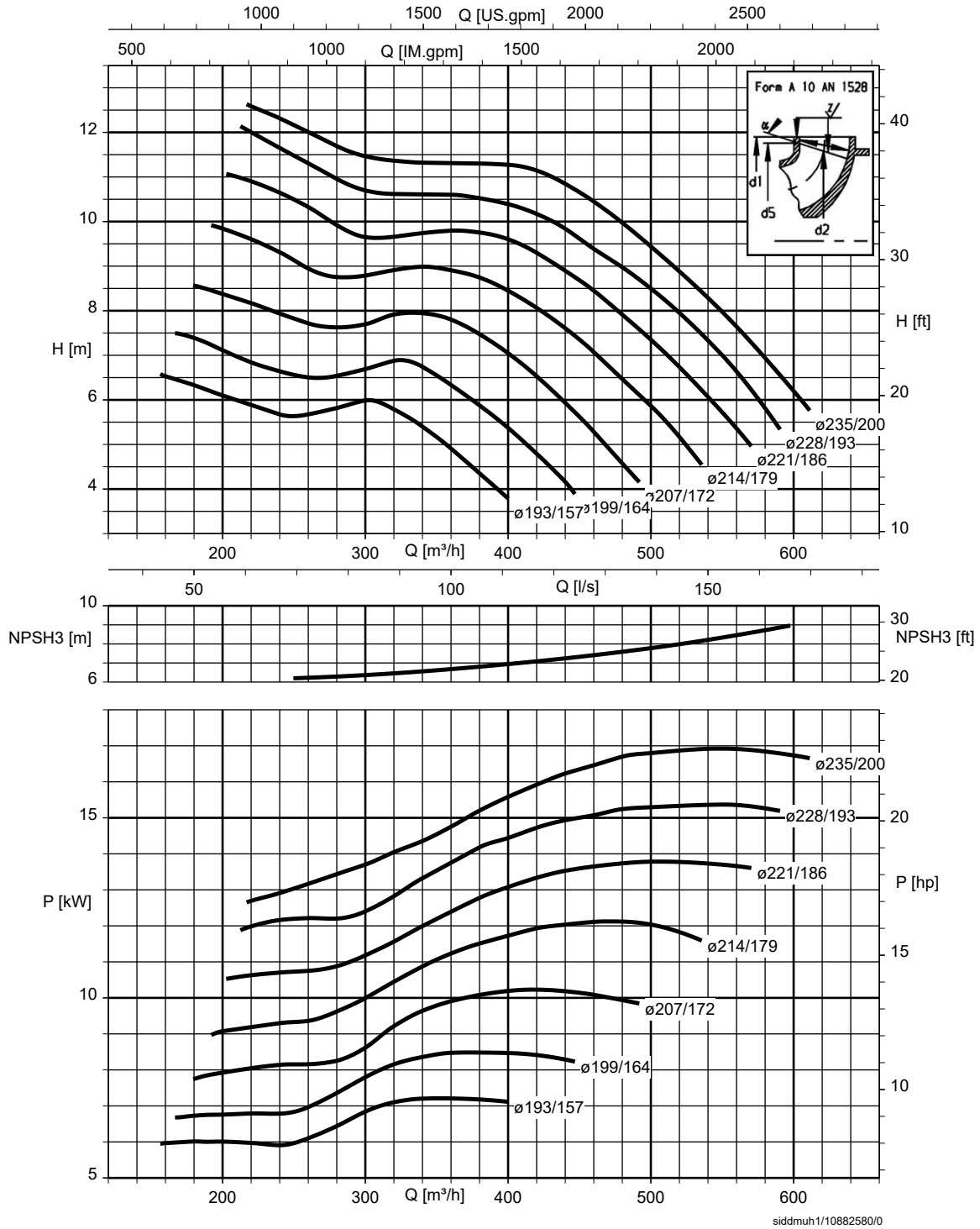

B14B, n = 1450 rpm

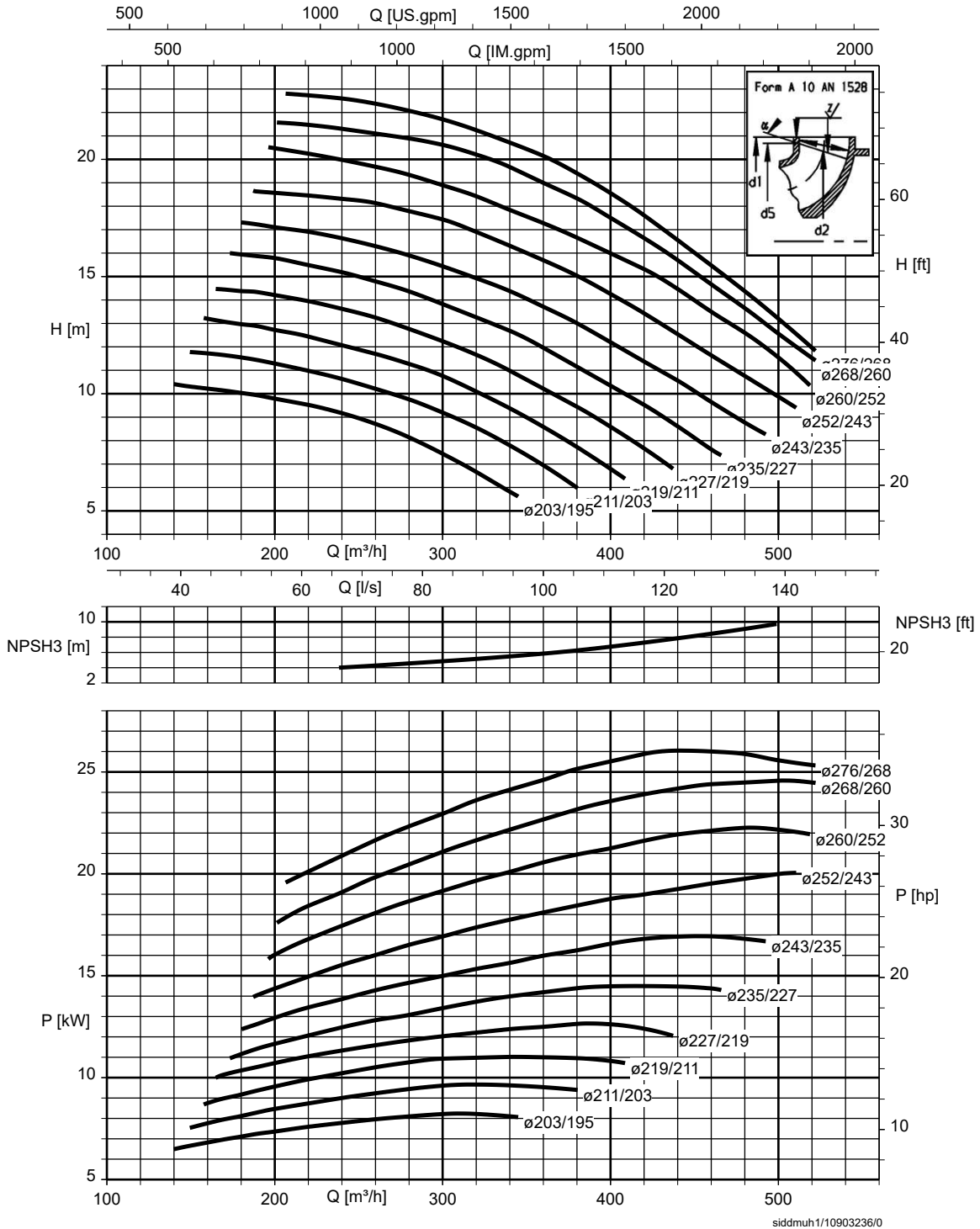

B14D, n = 1450 rpm

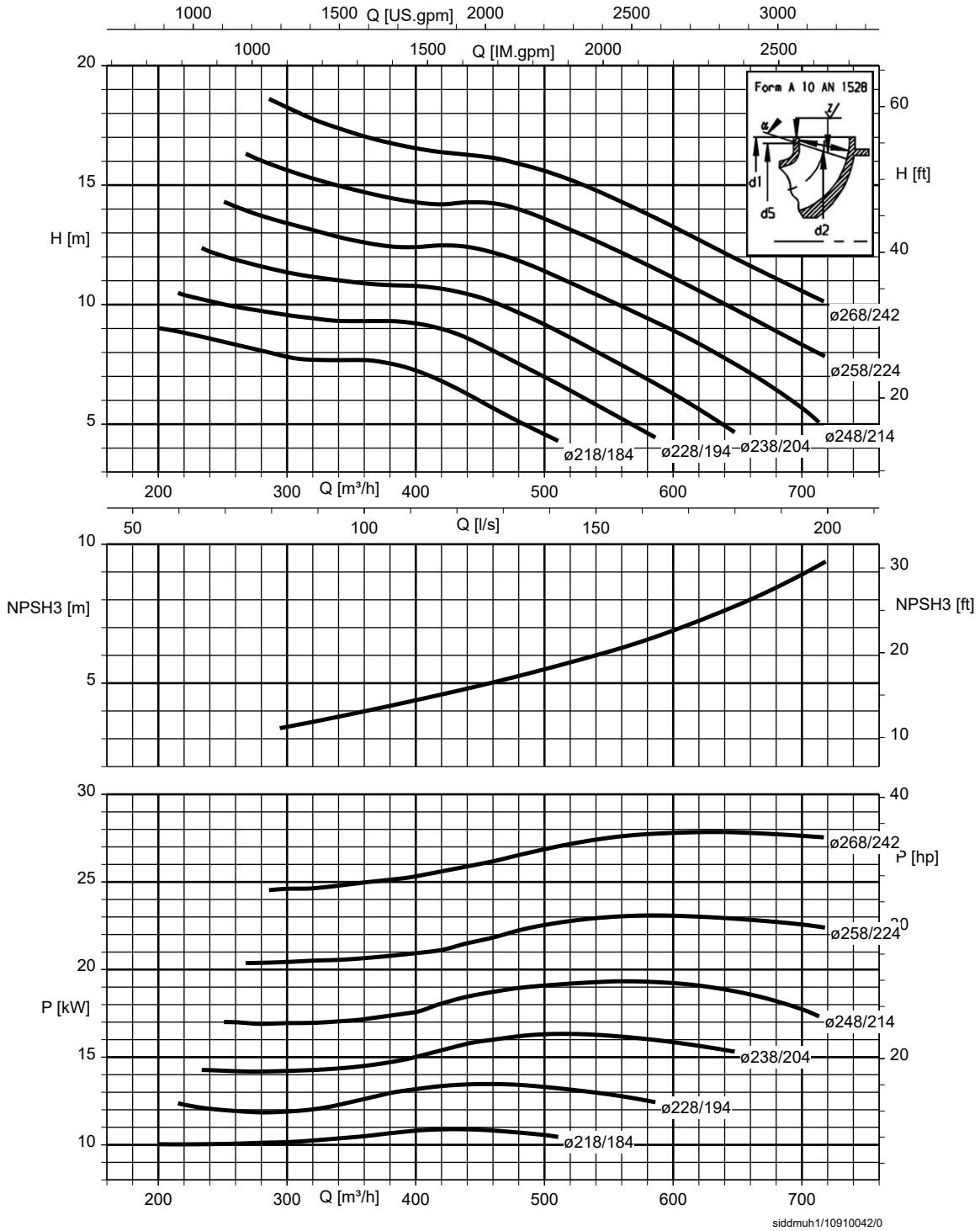

B16D, n = 1450 rpm

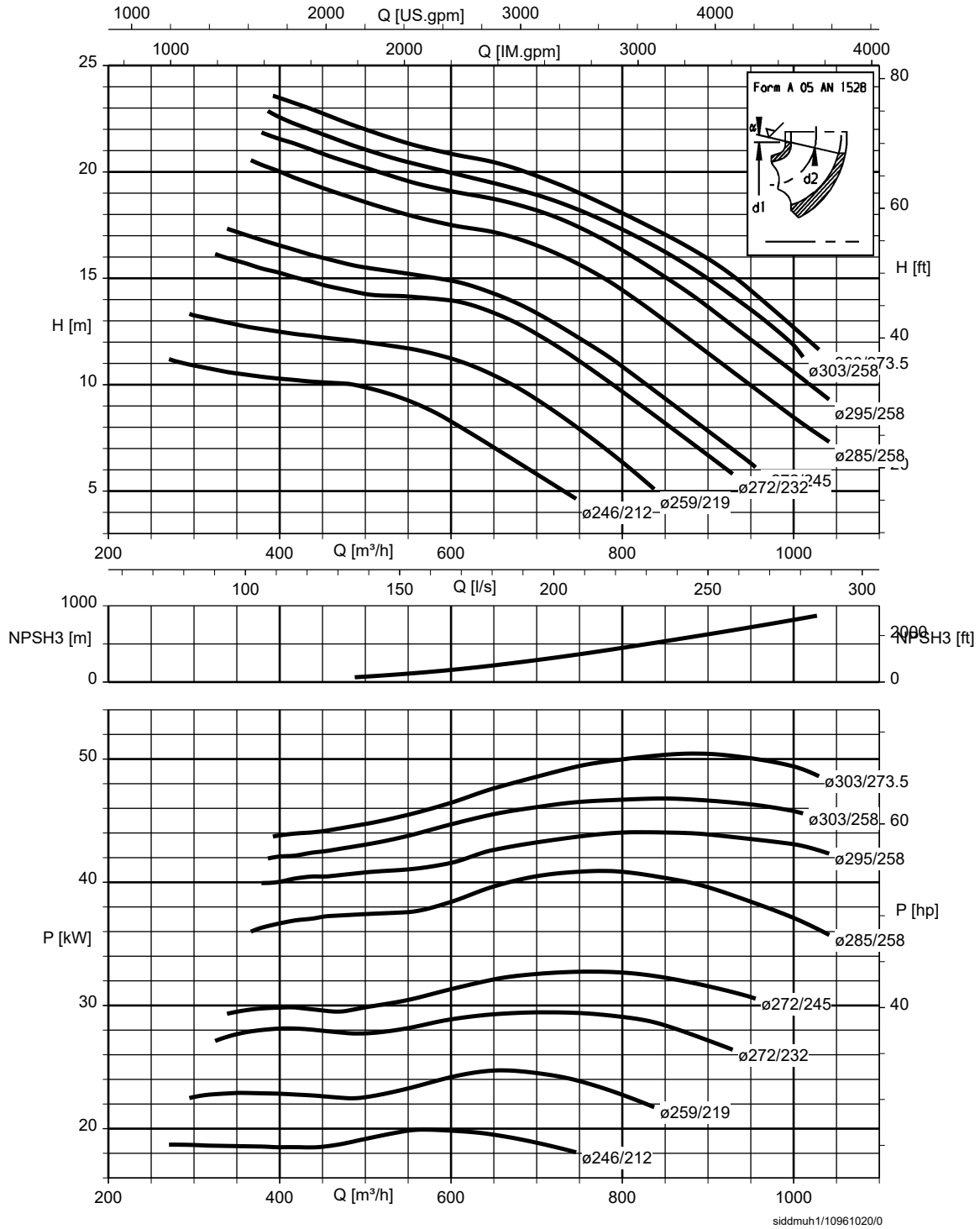

B18B, n = 1450 rpm

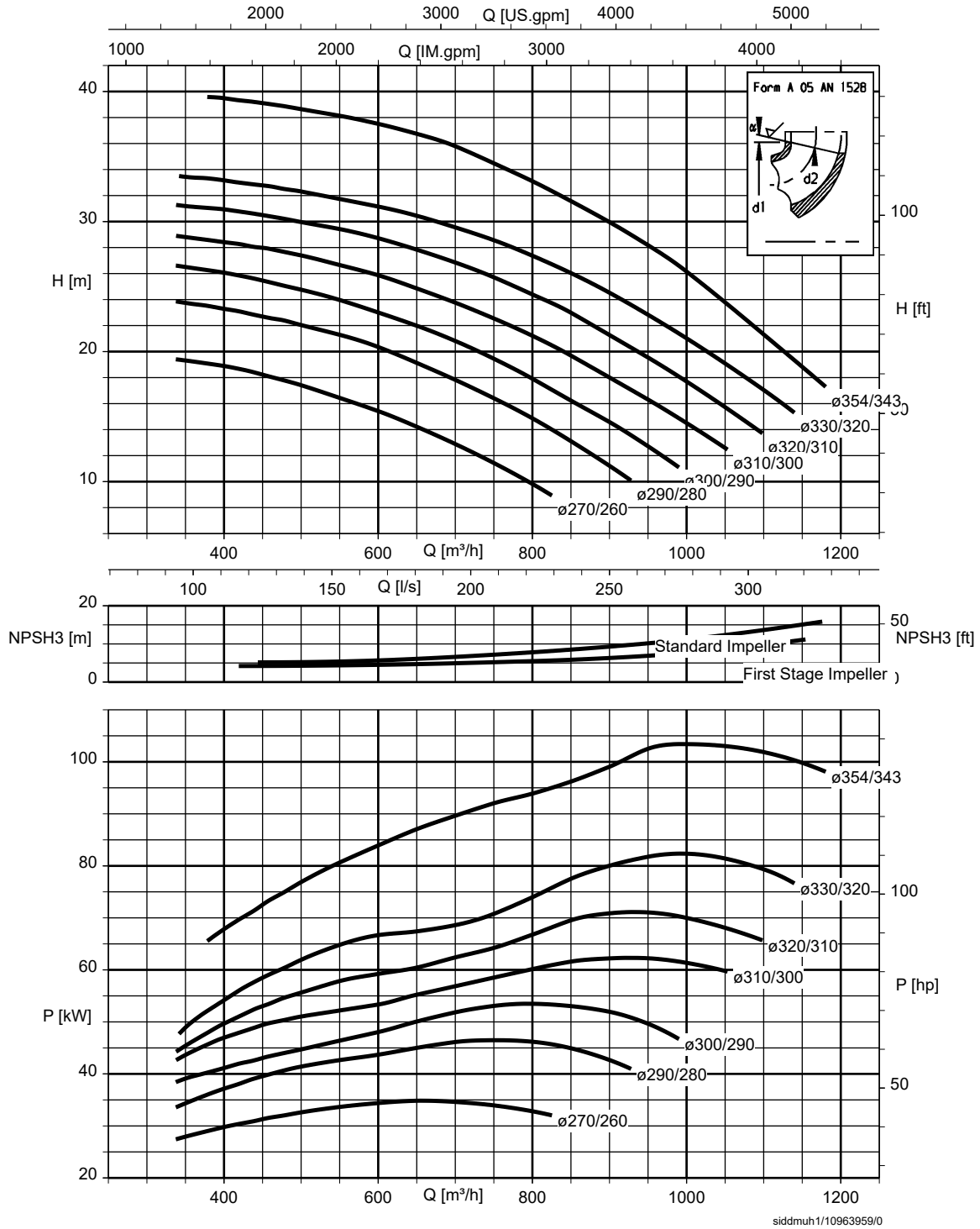

B20B, n = 1450 rpm

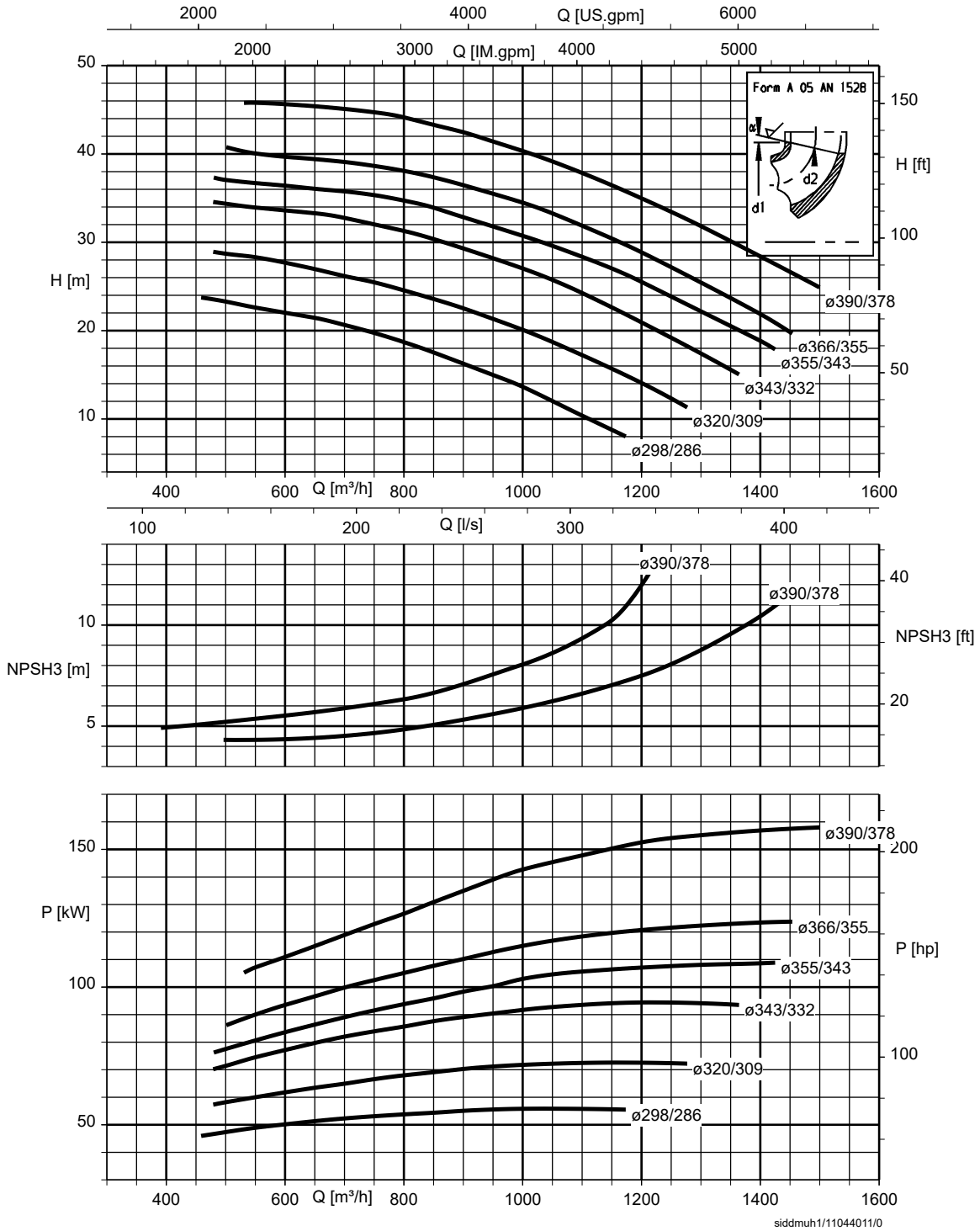

B22B, n = 1450 rpm

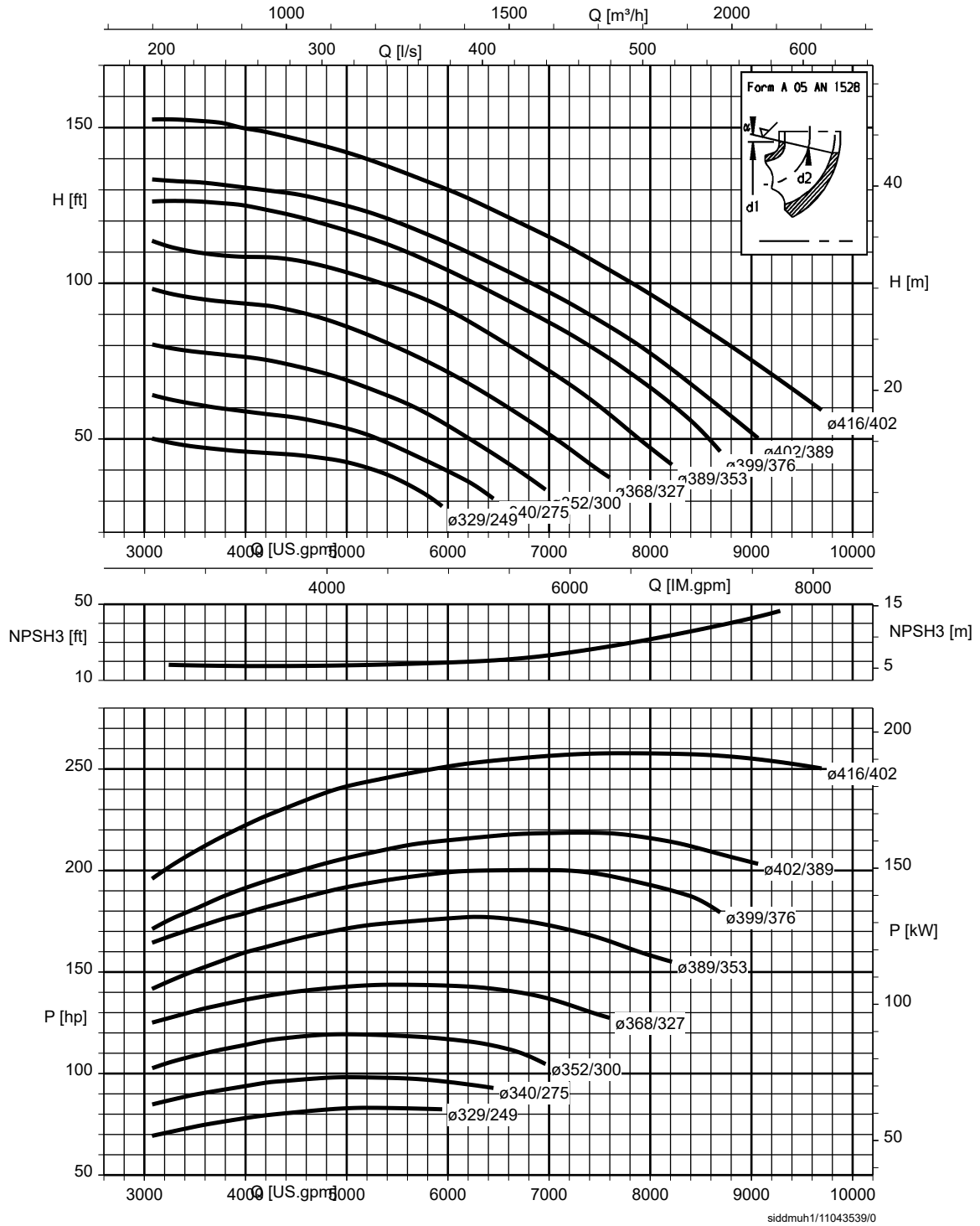

B24B, n = 1450 rpm

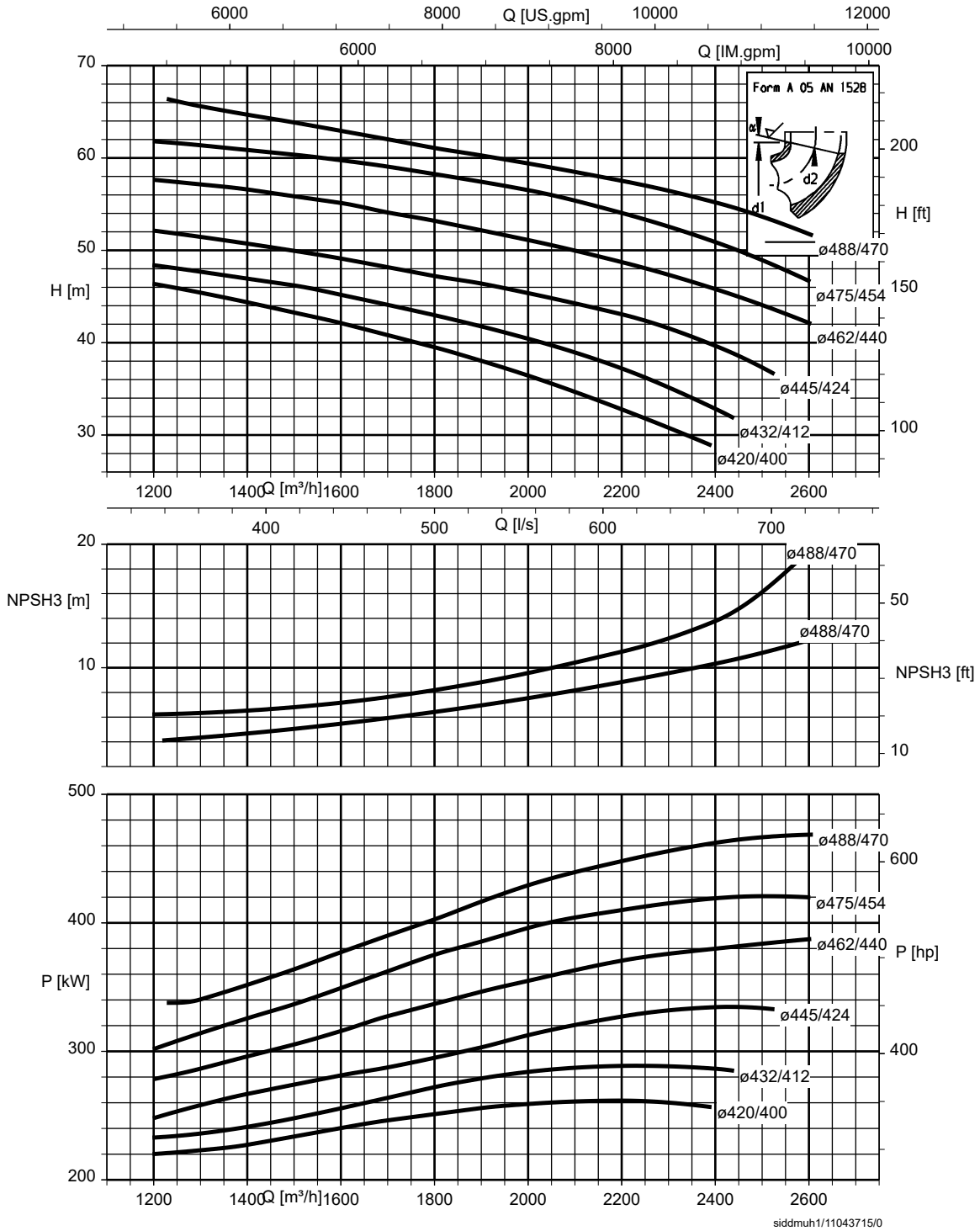

n = 980 rpm

B18B, n = 980 rpm

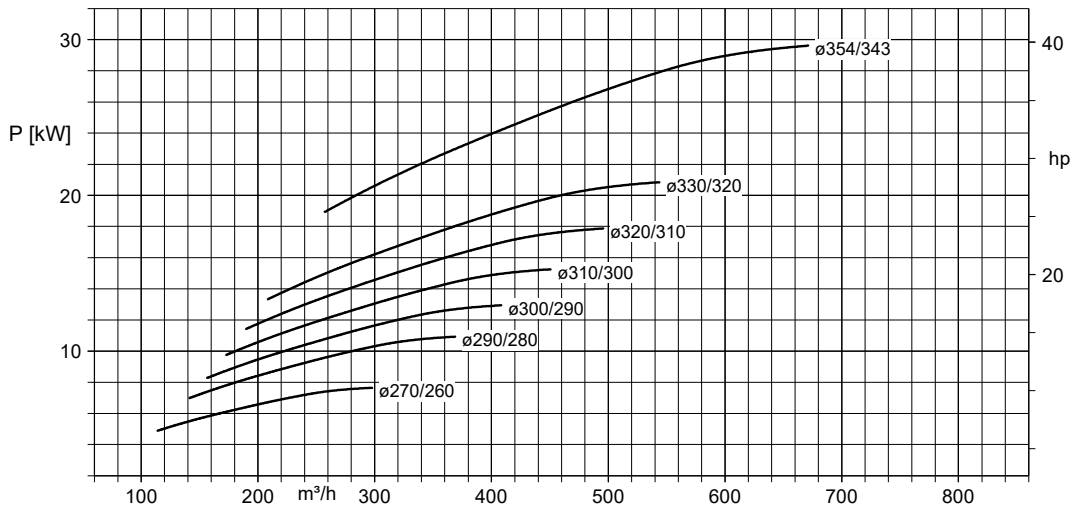
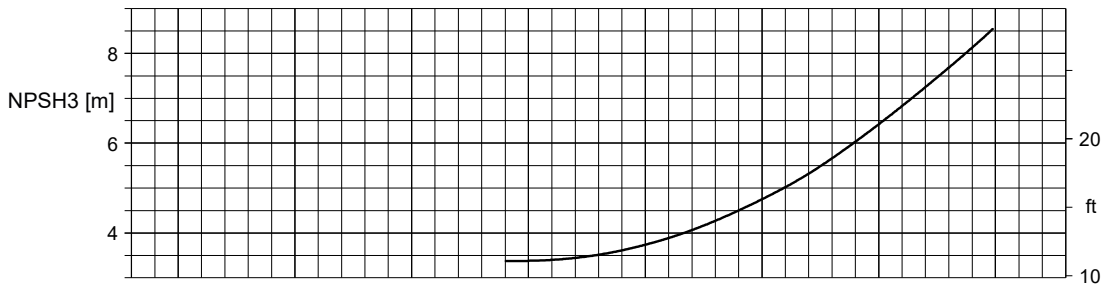
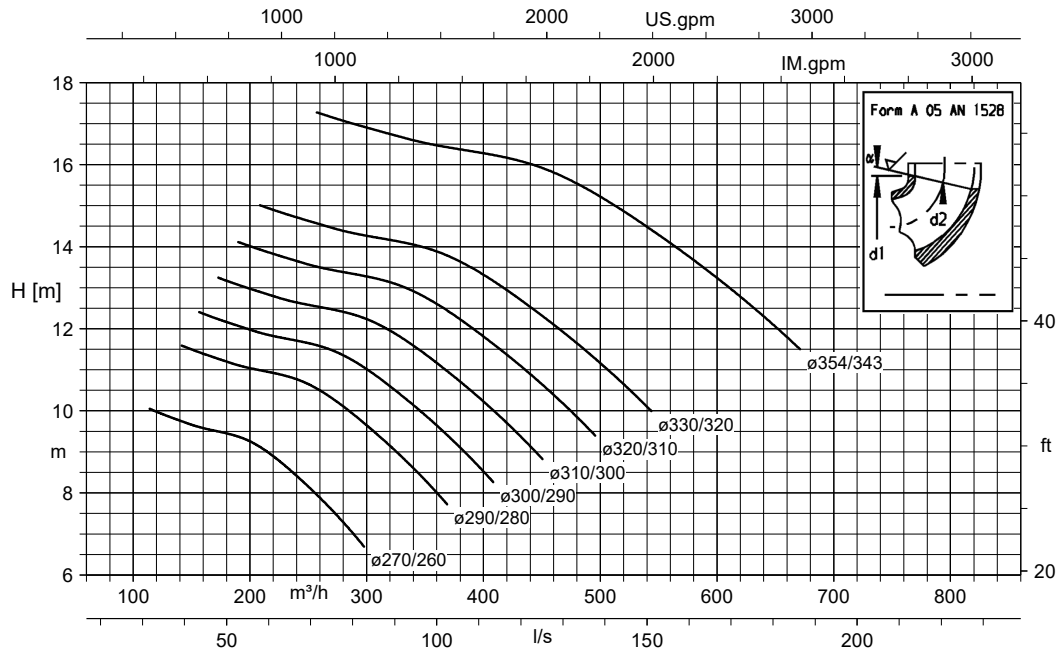

B18B@960 st1/1

3209.5/01-EN

B20B, n = 980 rpm

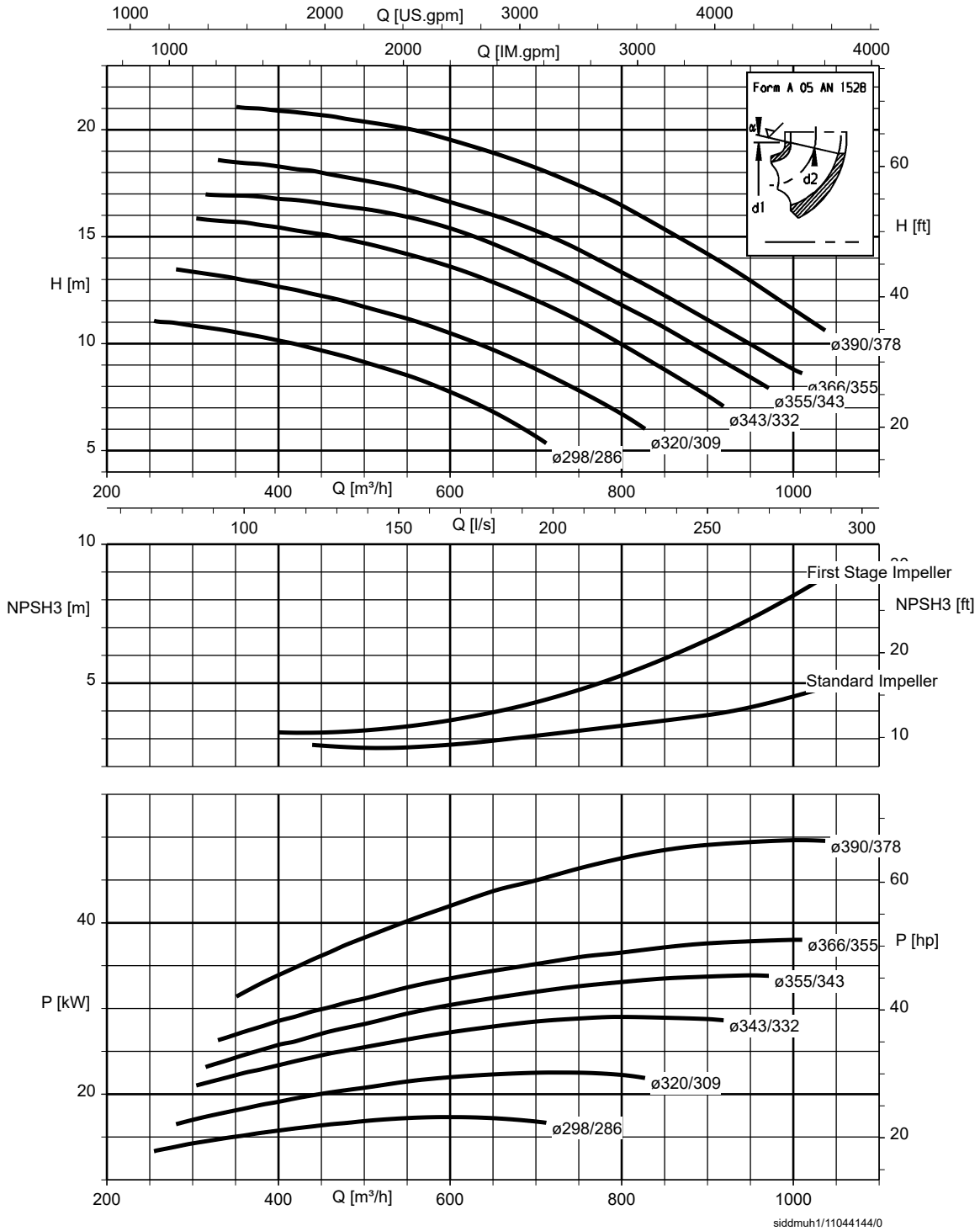

B22B, n = 980 rpm

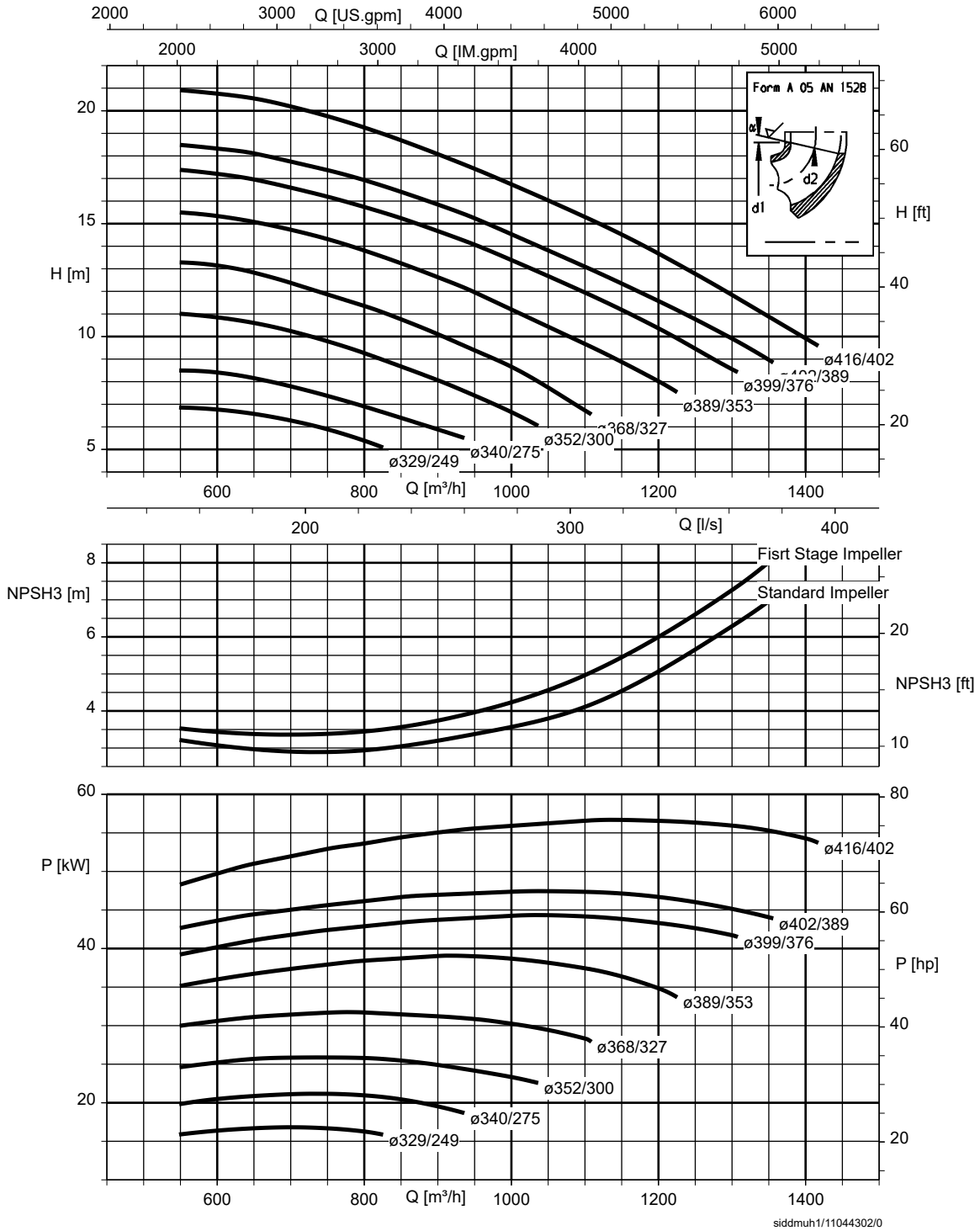

B24B, n = 980 rpm

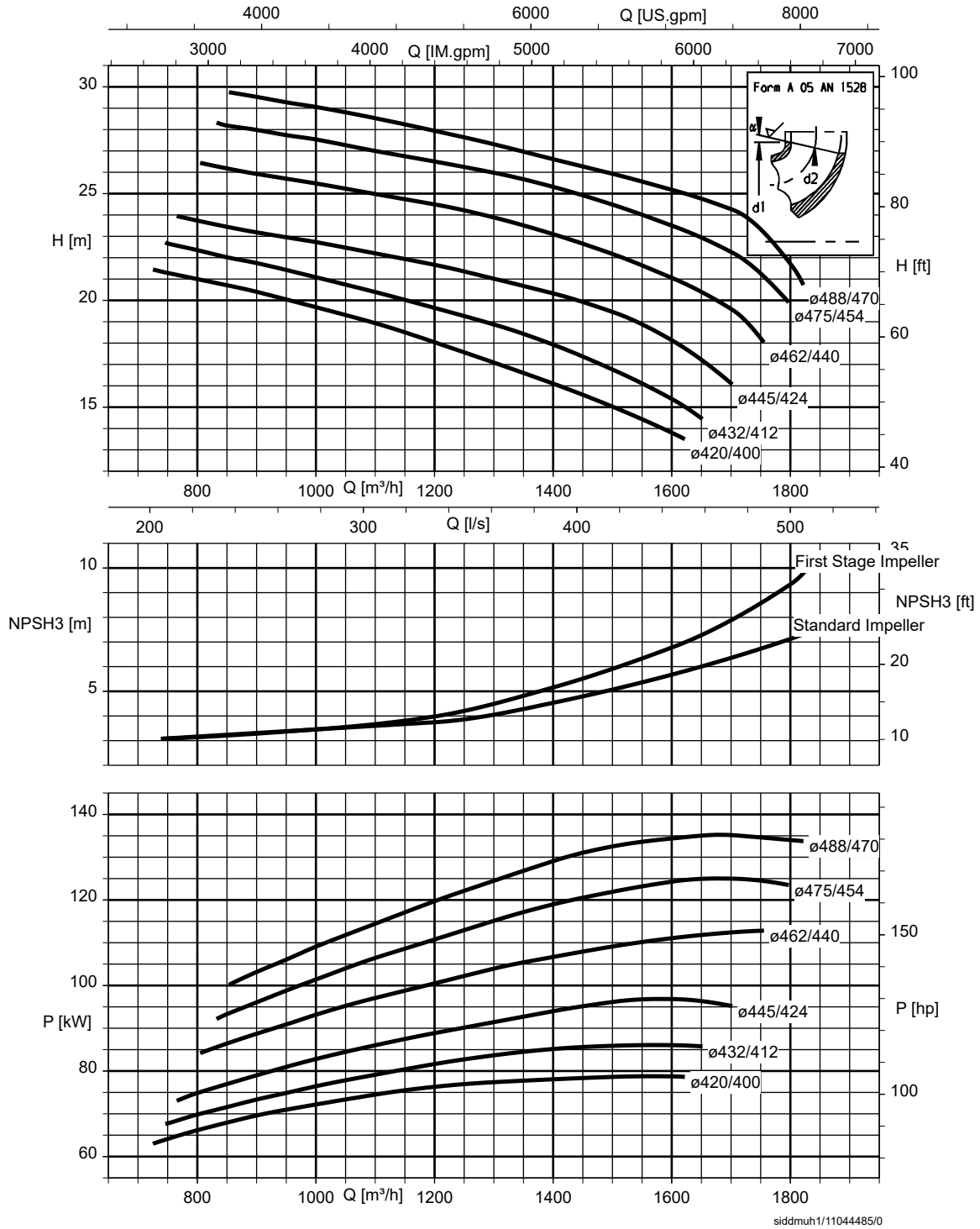

Dimensions and weights

Pump dimensions

Pump dimensions

Size	Impeller type	Max. number of stages			Stage length		Length of each additional stage	Max. length		Diameter	Suction strainer length		Column pipe diameter	Min. submergence of first-stage impeller	Suction strainer diameter	Foot valve length	Min. clearance between suction strainer and floor
		980 rpm	1450 rpm	2900 rpm	Flanged connection	Threaded connection		Flanged connection	Threaded connection		Flanged connection	Threaded connection					
					[mm]	[mm]	[mm]	[mm]	[mm]	[mm]	[mm]	[mm]	[inch]	[mm]	[inch]	[mm]	[mm]
B6	B	-	25	16	380	435	100	2780	2825	140	190	235	3, 4	300	4	135	100
B7	B	-	21	10	445	500	120	2845	2890	165	190	235	3, 4	300	4	135	100
B8	B	-	18	8	480	535	140	2860	2905	190	230	275	4, 5	350	5	165	125
	D	-	18	12	480	535	140	2860	2905	190	230	275	5, 6	350	5	165	125
B10	B	-	15	5	535	590	165	2845	2890	240	260	315	5, 6	400	6	185	150
	D	-	15	7	535	590	165	2845	2890	240	260	315	6, 7	400	6	185	150
	F	-	9	-	630	675	255	2830	2675	240	260	315	7	400	6	185	150
B12	B	-	12	-	580	625	200	2780	2875	290	295	310	7, 8	450	7	270	175
	D	-	12	-	580	625	200	2780	2875	290	295	310	8, 10	450	7	270	175
	F	-	8	-	745	745	300	2845	2845	290	340	390	10	450	8	365	200
B14	B	-	10	-	610	655	235	2725	2770	338	340	390	8, 10	450	8	365	200
	D	-	10	-	610	655	235	2725	2770	338	340	390	10	450	8	365	200
B16	D	-	8	-	690	735	270	2580	-	390	355	470	10, 12	450	10	410	250
B18	B	7	7	-	890	-	300	2690	-	430	540	540	12, 14	500	12	490	300
B20	B	6	6	-	955	-	335	2630	-	472	-	650	14, 16	500	14	560	350
B22	B	5	5	-	1050	-	400	2650	-	560	722	730	16, 18	500	16	600	400
B24	B	5	5	-	1050	-	410	2700	-	600	722	730	18, 20	500	16	630	400

Discharge nozzle dimensions

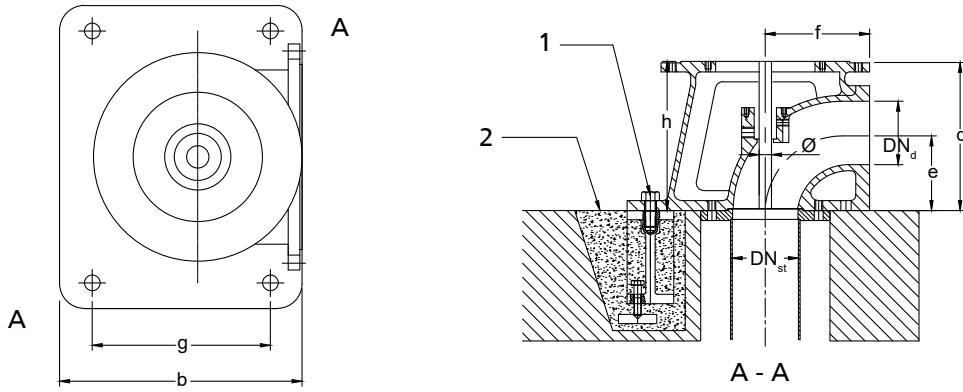

Fig. 1: Discharge nozzle dimensions VN 1342, 1342A, 1830 and 2030

1	Foundation bolt	2	Grout after pump installation.
---	-----------------	---	--------------------------------

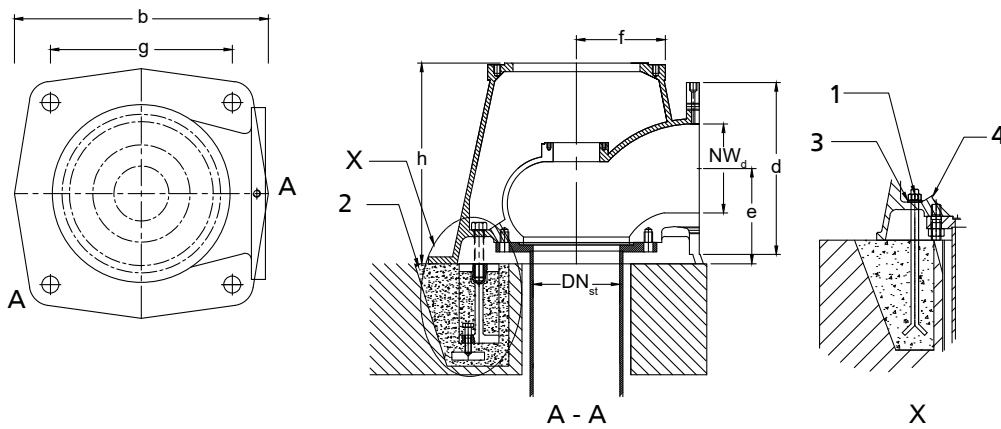

Fig. 2: Discharge nozzle dimensions VN 2541 and 2541A

1	Foundation bolt	2	Grout after pump installation.
3	Washer	4	Discharge casing

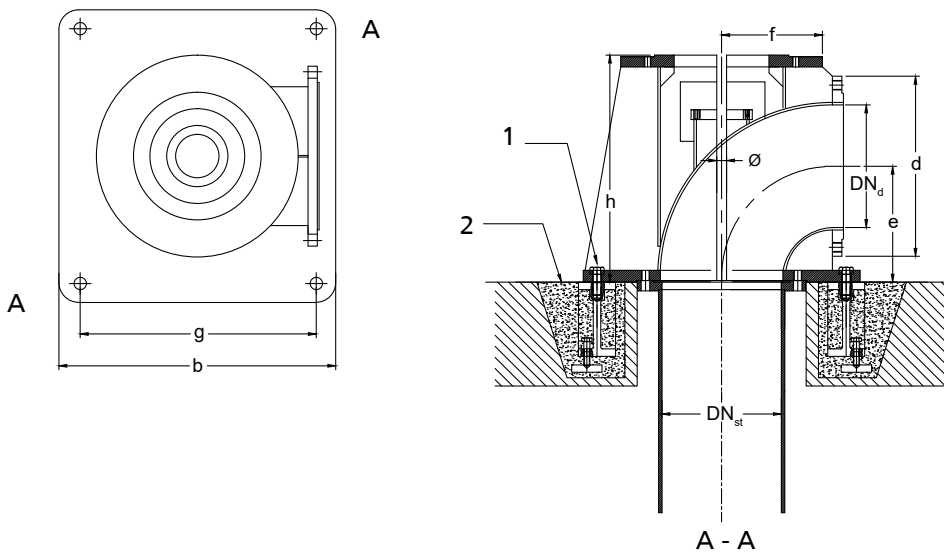

Fig. 3: Discharge nozzle dimensions VN 3051

1	Foundation bolt	2	Grout after pump installation.
---	-----------------	---	--------------------------------

Discharge nozzle dimensions

Discharge head	b	d	e	f	h	g	DN _{st}	Shaft diameter	DN _d	Foundation bolt	Material
	[mm]	[mm]	[mm]	[mm]	[mm]	[mm]	[mm]	[mm]	[mm]		
VN 1342A	425	As per flange standard	148	210	297	350	75, 100	25, 30, 35	100	M16 × 250	Grey cast iron
VN 1342	425		148	210	297	350	100, 125	25, 30, 35	125	M16 × 250	Grey cast iron
VN 1830	425		148	210	297	350	150, 175	25, 30, 35	150	M16 × 250	Grey cast iron
VN 2030	440		171,5	200	400	370	175, 200	25, 30, 35	200	M16 × 250	Grey cast iron
VN 2541A	600		225	290	470	430	200	25, 30, 35, 45	200	M16 × 300	Grey cast iron
VN 2541	600		225	290	470	430	250	30, 35, 45	250	M16 × 300	Grey cast iron
VN 3051	700		290	305	570	600	200, 250	30, 35, 45	300	M20 × 250	Steel

Weights
Bowl assembly

Weight of bowl assembly depending on size and number of stages

Size	Number of stages																									
	1	2	3	4	5	6	7	8	9	10	11	12	13	14	15	16	17	18	19	20	21	22	23	24	25	
	Weight of bowl assembly																									
	[kg]	[kg]	[kg]	[kg]	[kg]	[kg]	[kg]	[kg]	[kg]	[kg]	[kg]	[kg]	[kg]	[kg]	[kg]	[kg]	[kg]	[kg]	[kg]	[kg]	[kg]	[kg]	[kg]	[kg]	[kg]	[kg]
B6	22	28	34	40	46	52	58	64	70	76	82	88	94	100	106	112	118	124	130	136	142	148	154	160	166	
B7	32	41	50	59	68	77	86	95	104	113	122	131	140	149	158	167	176	185	194	203	212	-	-	-	-	
B8	44	56	68	80	92	104	116	128	140	152	164	176	188	200	212	224	236	248	-	-	-	-	-	-	-	
B10	72	96	120	144	168	192	216	240	264	288	312	336	360	384	408	-	-	-	-	-	-	-	-	-	-	
B12	112	154	195	238	280	322	364	406	448	490	532	574	-	-	-	-	-	-	-	-	-	-	-	-	-	
B14	160	222	284	346	408	470	532	594	686	718	-	-	-	-	-	-	-	-	-	-	-	-	-	-	-	
B16	220	305	390	475	560	645	730	815	-	-	-	-	-	-	-	-	-	-	-	-	-	-	-	-	-	
B18	295	407	519	631	743	855	967	-	-	-	-	-	-	-	-	-	-	-	-	-	-	-	-	-	-	
B20	385	545	705	865	1025	1185	-	-	-	-	-	-	-	-	-	-	-	-	-	-	-	-	-	-	-	
B22	530	785	1040	1295	1560	-	-	-	-	-	-	-	-	-	-	-	-	-	-	-	-	-	-	-	-	
B24	640	940	1240	1540	1840	-	-	-	-	-	-	-	-	-	-	-	-	-	-	-	-	-	-	-	-	

Column pipe set

Flanged connection

A standard column pipe set comprises:
 1 column pipe with 2 flanges
 1 bearing spider with bearing bush
 1 intermediate shaft with bearing sleeve
 1 intermediate shaft coupling
 1 set of fastening bolts/screws and O-rings

An upper column pipe set comprises:
 1 column pipe with 2 flanges
 1 intermediate shaft coupling
 1 set of fastening bolts/screws and O-rings

Threaded connection

A standard column pipe set comprises:
 1 column pipe with bearing bush
 1 intermediate shaft coupling
 1 set of fastening bolts/screws and O-rings

An upper column pipe set comprises:
 1 column pipe with 1 flanged end and 1 threaded end - max. length: 1220 mm
 1 intermediate shaft coupling
 1 set of fastening bolts/screws and O-rings

Weight of column pipe set, flanged version ³⁾ [kg]

Shaft diameter [mm]	Column pipe set	Column pipe diameter [mm]								
		80	100	125	150	200	250	300	350	400
20	1525	21,7	26,7	31,8	-	-	-	-	-	-
	2000	35,5	33,0	39,3	-	-	-	-	-	-
	2700	43,0	42,2	50,4	-	-	-	-	-	-
	3050	46,8	46,8	55,9	-	-	-	-	-	-
25	1525	-	26,7	34,7	58,6	80,1	-	-	-	-
	2000	-	33,0	42,9	72,5	97,7	-	-	-	-
	2700	-	42,2	54,9	92,9	123,7	-	-	-	-
	3050	-	46,8	61,0	103,1	136,6	-	-	-	-
30	1525	-	-	37,1	61,5	83,4	117,6	-	-	-
	2000	-	-	46,1	76,2	101,9	142,4	-	-	-
	2700	-	-	59,4	97,9	129,1	178,9	-	-	-
	3050	-	-	66,1	108,7	142,7	197,1	-	-	-
35	1525	-	-	-	64,1	88,3	115,8	148,6	-	-
	2000	-	-	-	79,7	107,6	141,4	181,4	-	-
	2700	-	-	-	102,6	136,1	179,1	229,7	-	-
	3050	-	-	-	114,0	150,3	197,9	253,9	-	-
45	1525	-	-	-	-	96,9	127,1	157,1	-	-
	2000	-	-	-	-	118,6	155,1	192,4	-	-
	2700	-	-	-	-	150,7	195,4	244,3	-	-
	3050	-	-	-	-	166,7	217,1	270,3	-	-
60	1525	-	-	-	-	-	-	174,4	231,2	303,3
	2000	-	-	-	-	-	-	191,4	251,8	328,9
	2700	-	-	-	-	-	-	246,9	319,1	412,8
	3050	-	-	-	-	-	-	268,5	345,3	445,3
70	1525	-	-	-	-	-	-	183,5	240,3	312,5
	2000	-	-	-	-	-	-	212,8	275,9	356,7
	2700	-	-	-	-	-	-	256,0	328,2	421,9
	3050	-	-	-	-	-	-	277,6	354,4	454,4

3209.5/01-EN

³⁾ Weight of threaded version = flanged version - 10 %

Discharge head

Discharge head type VN without drive lantern

Discharge head	Weight
	[kg]
VN 1342A	87
VN 1342	84
VN 1830	80
VN 2030	88
VN 2541A	165
VN 2541	165
VN 3051	170

Pump rotor

Weight of pump rotor

Size	1st stage	Each additional stage
	[kg]	[kg]
B6	2,4	1,2
B7	3,8	1,8
B8	5,6	2,8
B10	10,3	4,9
B12	17,2	8,4
B14	29,1	15,1
B16	38,5	21,7
B18	54	30,5
B20	67	41
B22	80	52
B24	94	63

 Weights of shaft enclosing tube, thrust bearing assembly, drive lantern and bearings on request.

Spare parts stock

Ordering spare parts

Always quote the following data when ordering replacement or spare parts:

- Order number
- Order item number
- Type series
- Material variant

Refer to the name plate for all data.

Also specify the following data:

- Part number and description (⇒ Page 47)
- Quantity of spare parts
- Shipping address
- Mode of dispatch (freight, mail, express freight, air freight)

Recommended spare parts stock for 2 years' operation to DIN 24296

Quantity of spare parts for recommended spare parts stock

Part No.	Description	Quantity	Note
211	Pump shaft	1	
212	Intermediate shaft	Z	
213	Top shaft	1	
230	Impeller	1	
271.1	Sand guard	1	
271.2	Sand guard	-	
320	Rolling element bearing	-	
321	Radial ball bearing	-	
382.1	Bearing carrier	1	
384	Thrust collar	1	
400.1	Gasket	1	
400.2	Gasket	5	
400.3	Gasket	1	
400.4	Gasket	2	
400.5	Gasket	1	
412.1	O-ring	1	
422.1	Felt ring	-	
422.2	Felt ring	-	
461	Gland packing (in metres)	-	
502	Casing wear ring	5	
521	Stage sleeve	S-1	From size B14
524	Shaft protecting sleeve	1	If applicable
526	Centring sleeve	-	
529	Bearing sleeve	1	
540	Bush	1	
541	Interstage bush	S-1	Cannot be used for sizes B6, B7, B14 and above
52-1	Clamping sleeve, complete	S	Up to and including size B12
544	Threaded bush	1	
545.1	Bearing bush	1	
545.2	Bearing bush / rubber	S	
545.3	Bearing bush	1	
851	Conical coupling	-	
852	Screwed coupling	Z + 1	
920.1	Nut with two flats	-	From size B14
931.1	Lock washer	-	From size B14
931.2	Lock washer	-	

Installation depths
Possible column pipe connections

Symbols key

Symbol	Description
X	Combination possible
-	Not available

Possible column pipe connections

Size	Threaded connection [Zoll]									Flanged connection [mm]										
	3	4	5	6	7	8	10	12	14	80	100	125	150	175	200	250	300	350	400	500
B6B	X	X	-	-	-	-	-	-	-	X	X	-	-	-	-	-	-	-	-	-
B7B	-	X	X	-	-	-	-	-	-	-	X	X	-	-	-	-	-	-	-	-
B8B	-	X	X	-	-	-	-	-	-	-	X	X	-	-	-	-	-	-	-	-
B8D	-	-	X	X	-	-	-	-	-	-	-	X	X	-	-	-	-	-	-	-
B10B	-	-	X	X	-	-	-	-	-	-	-	X	X	-	-	-	-	-	-	-
B10D	-	-	-	X	X	-	-	-	-	-	-	-	X	X	-	-	-	-	-	-
B10F	-	-	-	-	X	-	-	-	-	-	-	-	-	X	-	-	-	-	-	-
B12B	-	-	-	-	X	X	-	-	-	-	-	-	-	-	X	X	-	-	-	-
B12D	-	-	-	-	-	X	X	X	-	-	-	-	-	-	-	X	-	-	-	-
B12F	-	-	-	-	-	-	-	X	X	-	-	-	-	-	X	X	-	-	-	-
B14B	-	-	-	-	-	-	X	X	X	-	-	-	-	-	X	X	-	-	-	-
B14D	-	-	-	-	-	-	-	X	X	-	-	-	-	-	-	X	-	-	-	-
B16D	-	-	-	-	-	-	-	-	-	-	-	-	-	-	-	X	X	-	-	-
B18B	-	-	-	-	-	-	-	-	-	-	-	-	-	-	-	-	-	-	X	-
B20B	-	-	-	-	-	-	-	-	-	-	-	-	-	-	-	-	-	-	X	X
B22B	-	-	-	-	-	-	-	-	-	-	-	-	-	-	-	-	-	-	X	X
B24B	-	-	-	-	-	-	-	-	-	-	-	-	-	-	-	-	-	-	-	X

General drawings with list of components

Sectional drawing with list of components

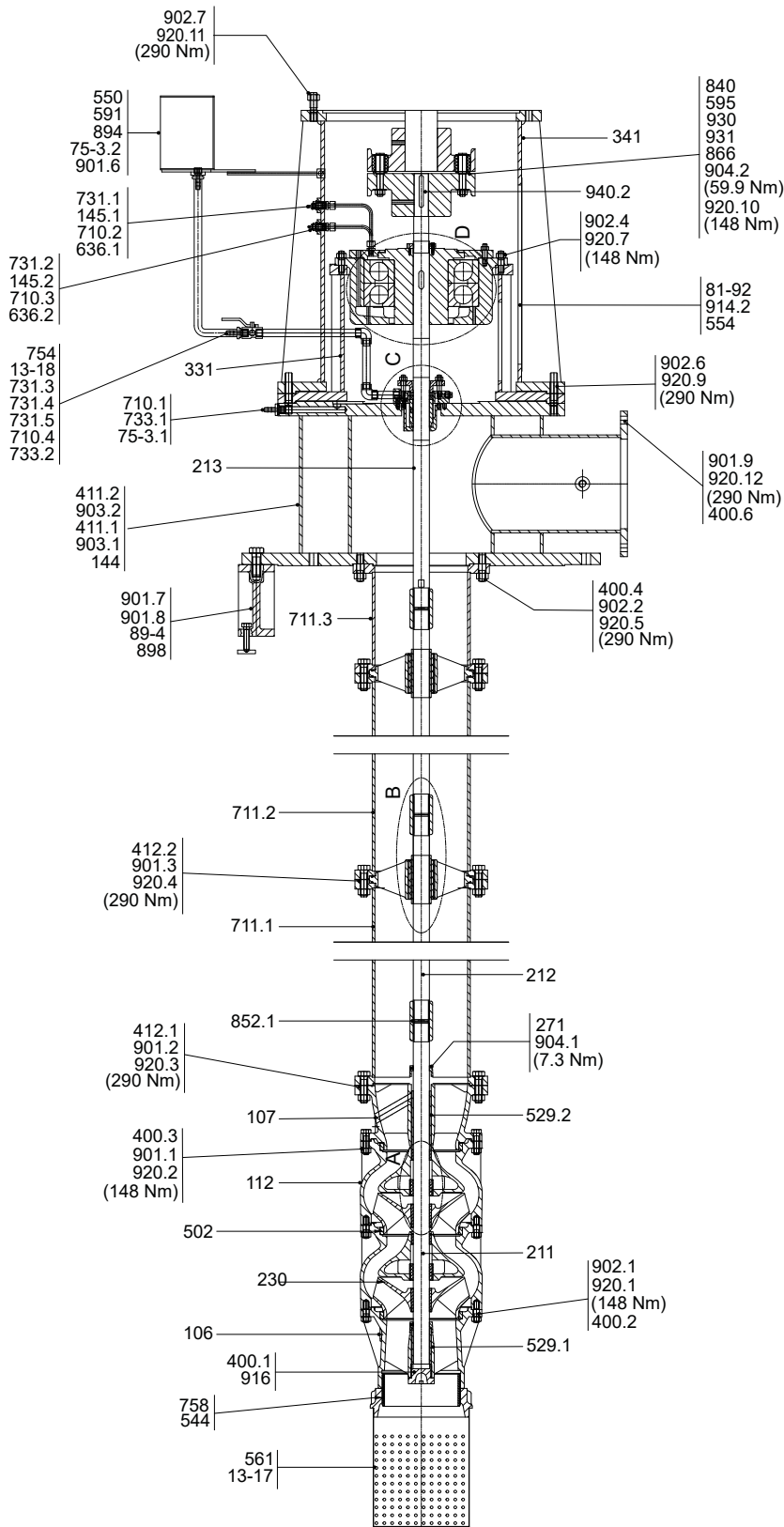

Fig. 4: Sectional drawing with list of components

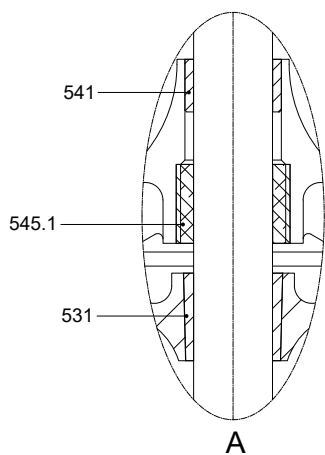

Fig. 5: Detail A

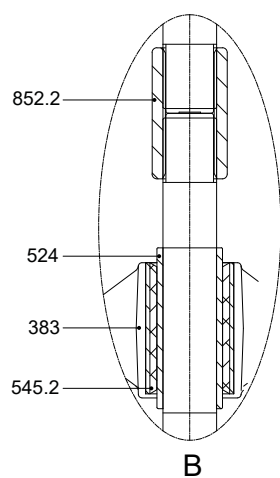

Fig. 6: Detail B

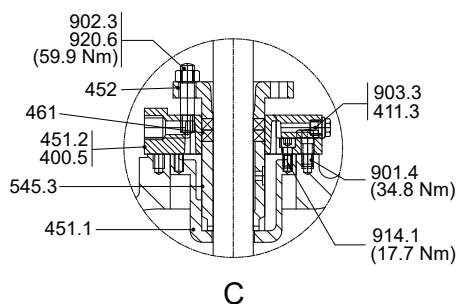

Fig. 7: Detail C

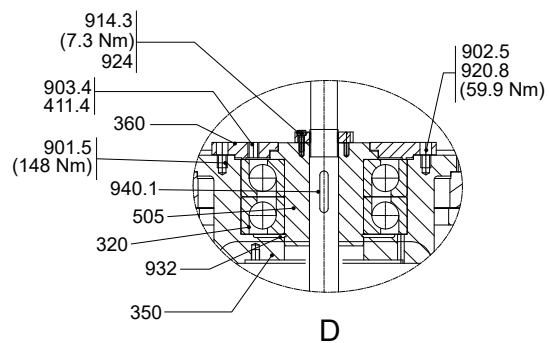

Fig. 8: Detail D

List of components

Part No.	Description	Part No.	Description
13-17	Strainer	545.1./2./3	Bearing bush
13-18	Elbow	554	Washer
106	Suction casing	561	Grooved pin
107	Discharge casing	591	Tank
112	Pump bowl	595	Anti-vibration pad
144	Discharge elbow	636.1./2	Lubricating nipple
145.1./2	Adapter	75-3.1/3.2	Nozzle
211	Pump shaft	710.1./2./3./4	Pipe
212	Intermediate shaft	711.1./2./3	Column pipe
213	Top shaft	731.1./2./3./4./5	Pipe union
230	Impeller	733.1./2	Pipe clamp
271	Sand guard	754	Valve ball
320	Rolling element bearing	758	Screen
331	Bearing pedestal	81-92	Cover plate
341	Drive lantern	89-4	Shim
350	Bearing housing	840	Coupling
360	Bearing cover	852.1./2	Screwed coupling
383	Bearing spider	866	Coupling bolt
400.1./2./3./4./5./6	Gasket	894	Mounting bracket
411.1./2./3./4	Joint ring	898	Foundation block
412.1./2	O-ring	901.1./2./3./4./5./6./7./8./9	Hexagon head bolt
451.1./2	Stuffing box housing	902.1./2./3./4./5./6./7	Stud
452	Gland follower	903.1./2./3./4	Screw plug
461	Gland packing	904.1./2	Grub screw
502	Casing wear ring	914.1./2./3	Hexagon socket head cap screw
505	Loose collar	916	Plug
524	Shaft protecting sleeve	920.1./2./3./4./5./6./7./8./9/ .10/.11/.12	Nut
529.1./2	Bearing sleeve	924	Adjusting nut
531	Locking sleeve	930	Safety device
541	Interstage bush	931	Lock washer
550	Disc	932	Circlip
544	Threaded bush	940.1./2	Key

Bowl assembly

Flanged pump

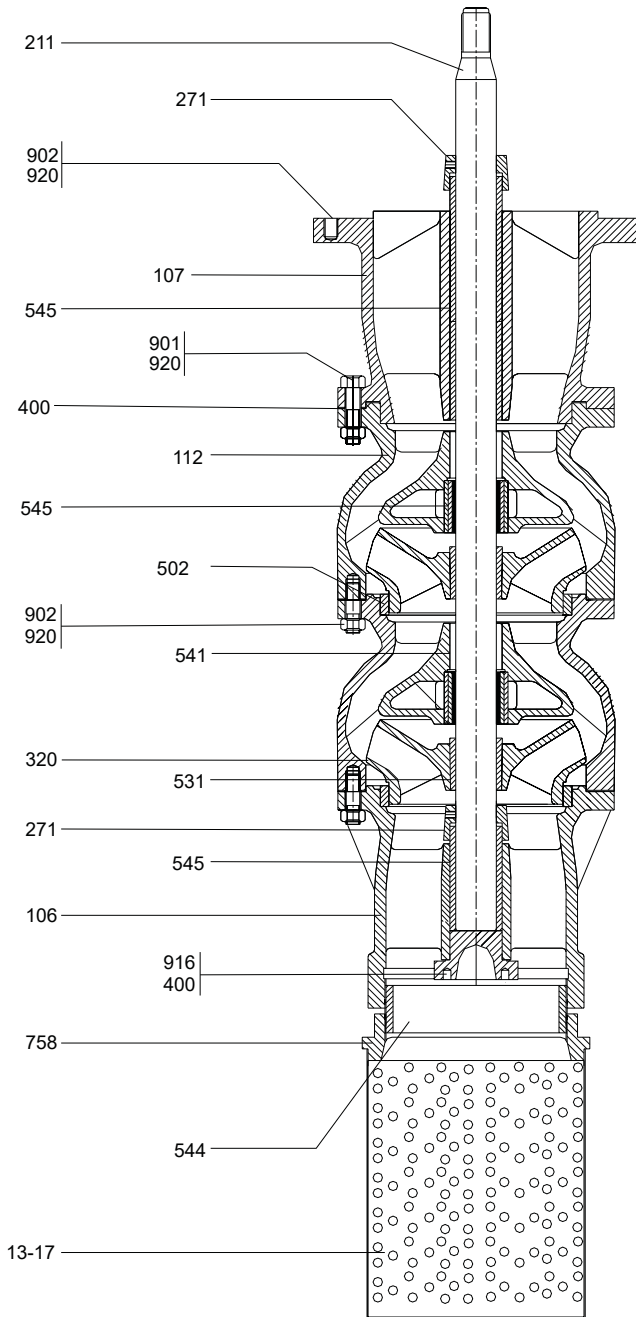

Fig. 9: Flanged pump

List of components

Part No.	Description	Part No.	Description
13-17	Strainer	531	Locking sleeve
106	Suction casing	541	Interstage bush
107	Discharge casing	544	Threaded bush
112	Pump bowl	545	Bearing bush
211	Pump shaft	758	Screen
271	Sand guard	901	Hexagon head bolt
320	Rolling element bearing	902	Stud
400	Gasket	916	Plug
502	Casing wear ring	920	Nut

3209.5/01-EN

Sectional drawing of sizes B18 to B24

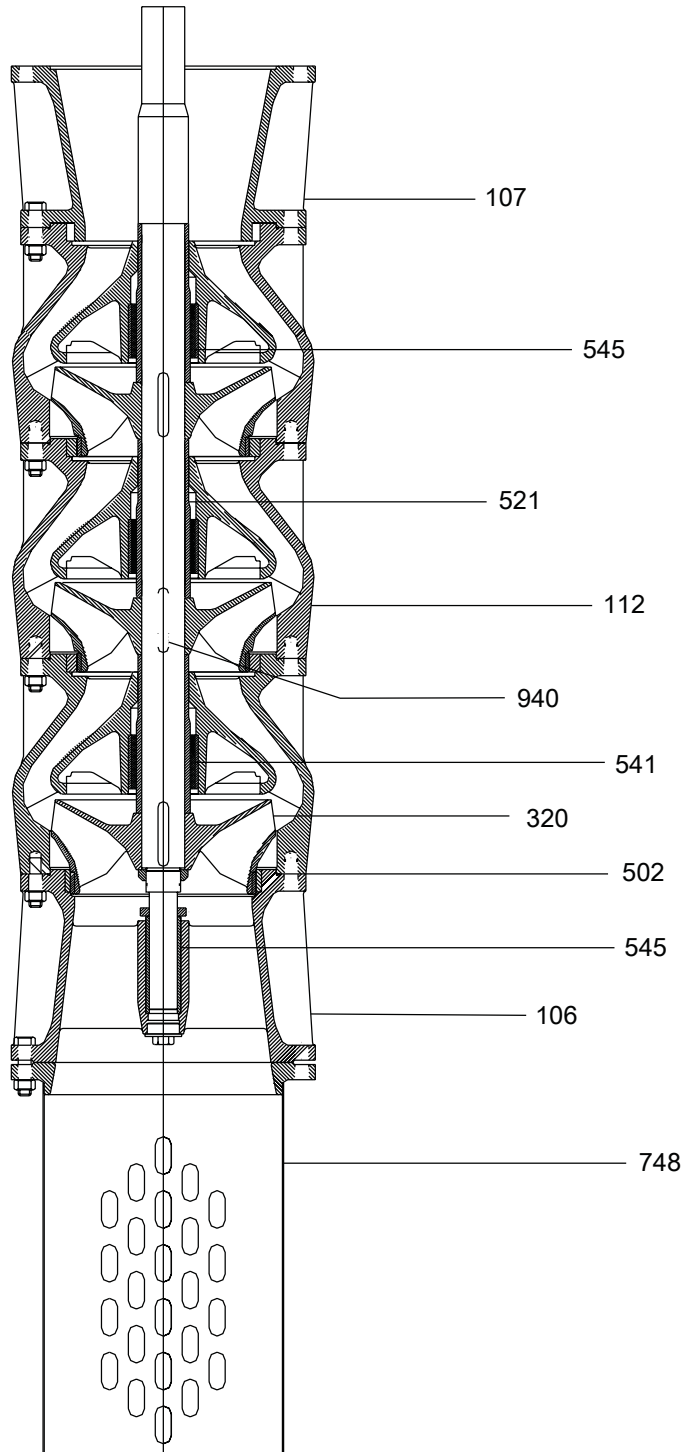

Fig. 10: Sectional drawing of sizes 18 to 24

List of components

Part No.	Description	Part No.	Description
106	Suction casing	521	Stage sleeve
107	Discharge casing	541	Interstage bush
112	Pump bowl	545	Bearing bush
320	Rolling element bearing	748	Suction strainer
502	Casing wear ring	940	Key

3209.5/01-EN

Column pipe

Column pipe with shaft enclosing tube

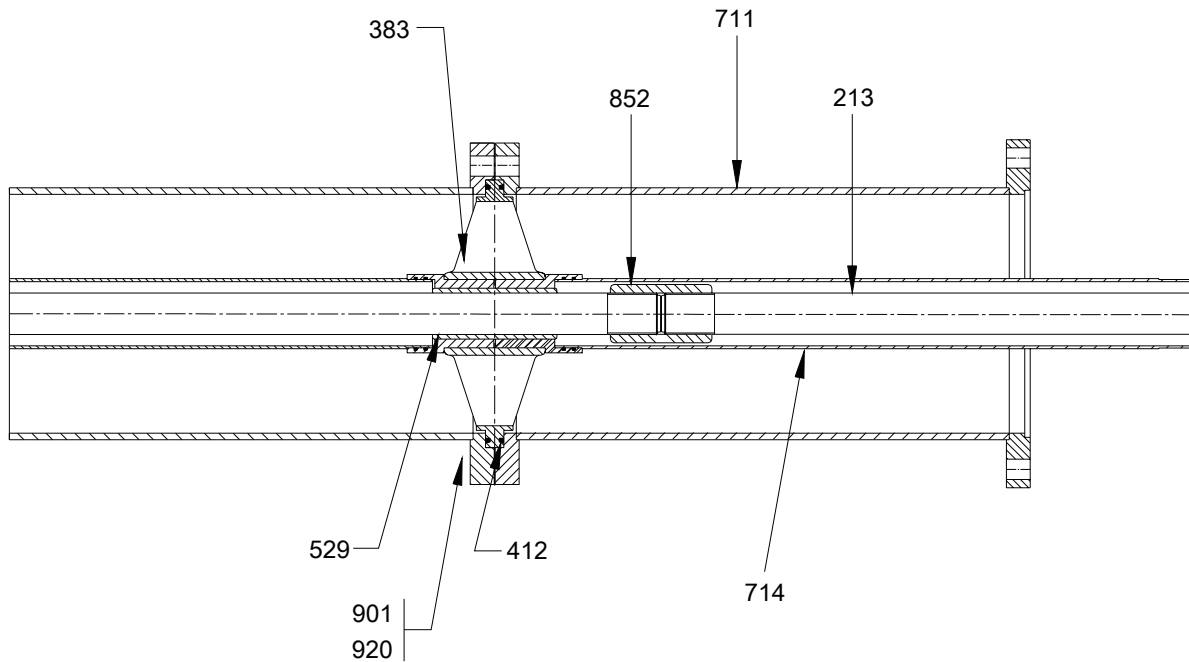

Fig. 11: Column pipe with shaft enclosing tube

List of components

Part No.	Description	Part No.	Description
213	Top shaft	714	Shaft enclosing tube
383	Bearing spider	852	Screwed coupling
412	O-ring	901	Hexagon head bolt
529	Bearing sleeve	920	Nut
711	Column pipe		

Column pipe with flanged ends

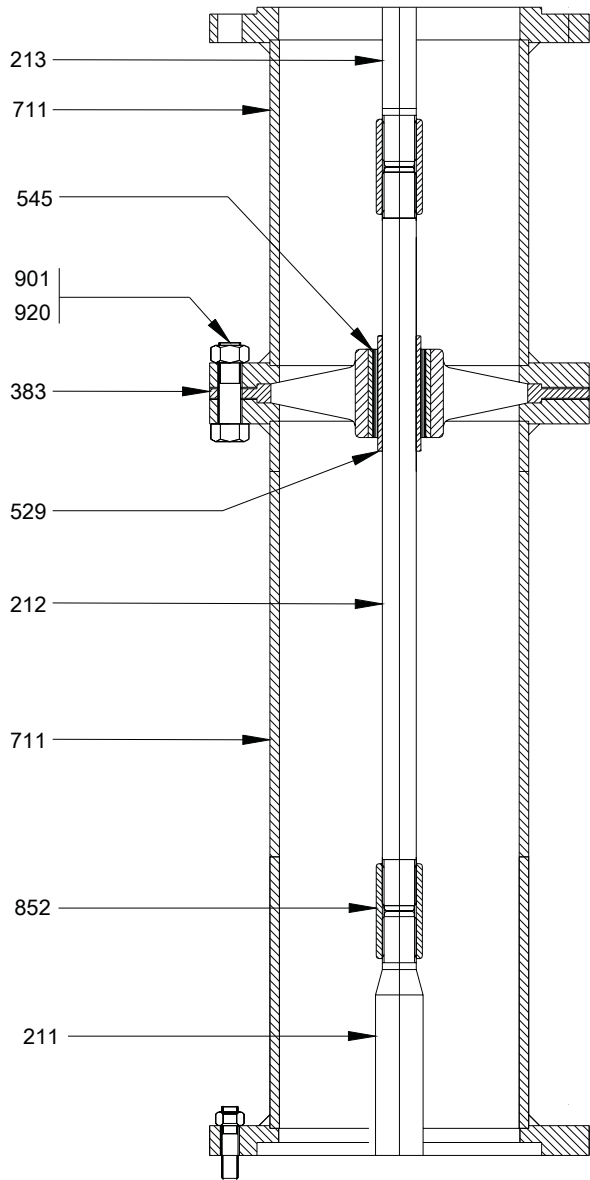

Fig. 12: Column pipe with flanged ends

List of components

Part No.	Description	Part No.	Description
211	Pump shaft	545	Bearing bush
212	Intermediate shaft	711	Column pipe
213	Top shaft	852	Screwed coupling
383	Bearing spider	901	Hexagon head bolt
529	Bearing sleeve	920	Nut

Drive end

Lubricating device for shaft enclosing tube

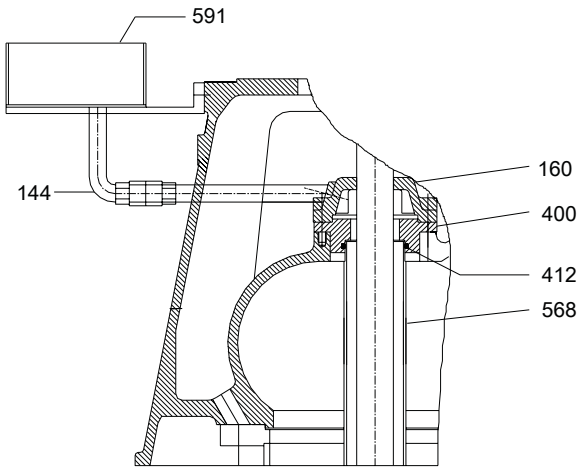

Fig. 13: Lubricating device for shaft enclosing tube

List of components

Part No.	Description	Part No.	Description
144	Pump shaft	412	O-ring
160	Cover	591	Tank
400	Gasket		

Discharge casing for shaft enclosing tube

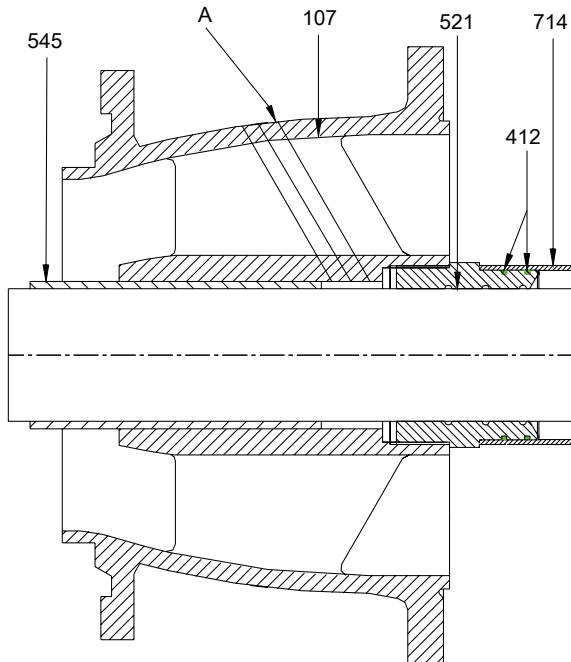

Fig. 14: Discharge casing for shaft enclosing tube

List of components

Part No.	Description	Part No.	Description
A	Lubricant drain	545	Bearing bush
107	Discharge casing	521	Stage sleeve
412	O-ring	714	Shaft enclosing tube

Stuffing box housing for shaft enclosing tube

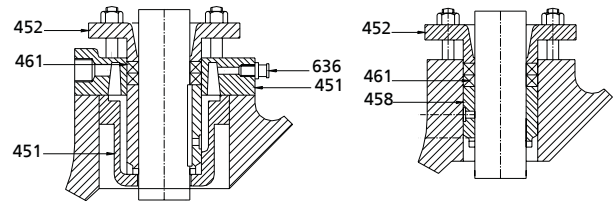

Fig. 15: Stuffing box housing for shaft enclosing tube

List of components

Part No.	Description	Part No.	Description
451	Stuffing box housing	461	Gland packing
452	Gland follower	636	Lubricating nipple
458	Lantern ring		

Drive lantern with thrust bearing assembly

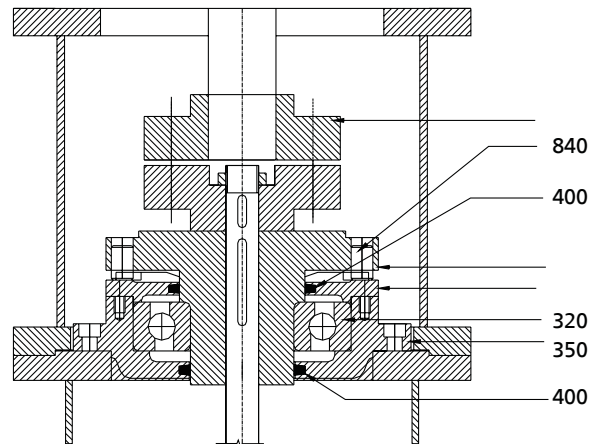

Fig. 16: Drive lantern with thrust bearing assembly

List of components

Part No.	Description	Part No.	Description
320	Rolling element bearing	400	Gasket
350	Bearing housing	840	Coupling

Drive lantern with double bearing assembly

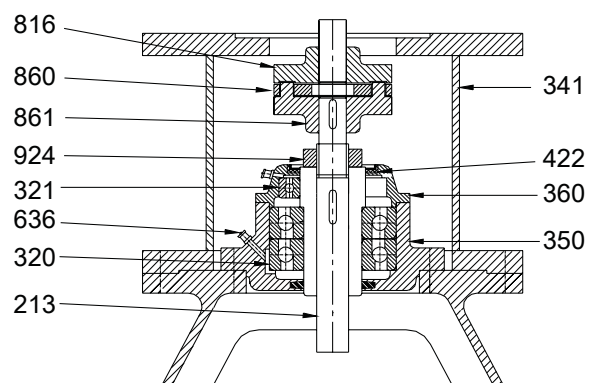

Fig. 17: Drive lantern with double bearing assembly

List of components

Part No.	Description	Part No.	Description
213	Top shaft	422	Felt ring
320	Rolling element bearing	636	Lubricating nipple
321	Radial ball bearing	816	Stator tube

Part No.	Description	Part No.	Description
341	Drive lantern	860	Coupling part
350	Bearing housing	861	Half coupling

Part No.	Description	Part No.	Description
360	Bearing cover	924	Adjusting nut

Drive lantern with solid shaft and stuffing box housing

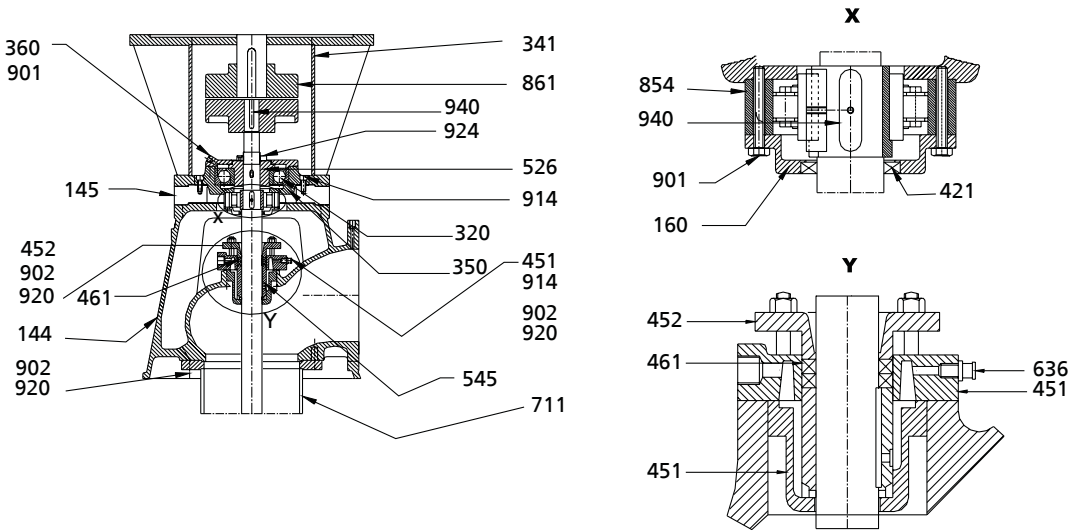

Fig. 18: Drive lantern with solid shaft and stuffing box housing

List of components

Part No.	Description	Part No.	Description
144	Discharge elbow	545	Bearing bush
145	Adapter	636	Lubricating nipple
160	Cover	711	Column pipe
320	Rolling element bearing	854	Backstop
341	Drive lantern	861	Half coupling
350	Bearing housing	901	Hexagon head bolt
360	Bearing cover	902	Stud
421	Lip seal	914	Hexagon socket head cap screw
451	Stuffing box housing	920	Nut
452	Gland follower	924	Adjusting nut
461	Gland packing	940	Key
526	Centring sleeve		



KSB Pumps Company Limited
16/2 Sir Aga Khan Road
Lahore (Pakistan)
UAN: +92-42-11-572-786
Tel: +92-42-36304173-74
Fax: +92-42-36366192, 36368878
E-Mail: info@ksb.com.pk
www.ksb.com.pk